

Action

crawling figure
in distance

Dial

<SFX> (OS)
grunting

SLG

Trans

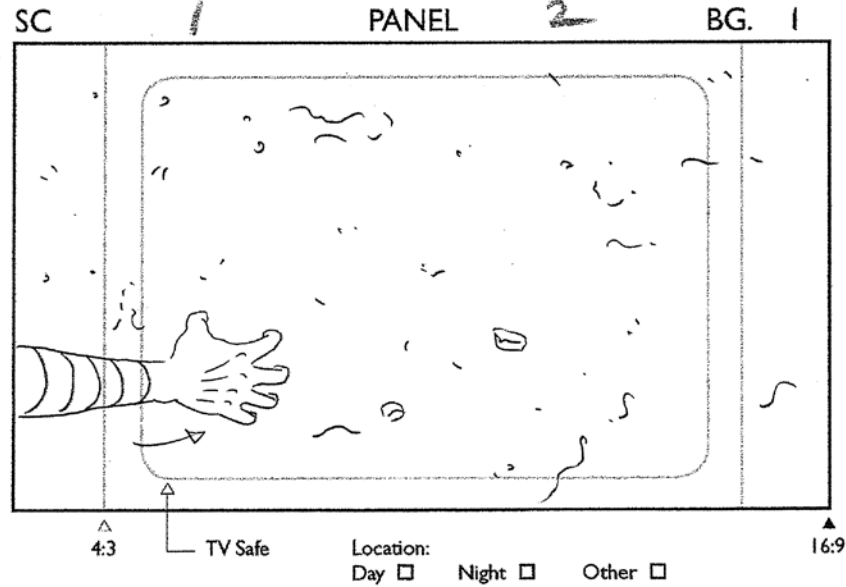

Action

SOKKA's right
hand slowly with
effort dig into the ground

Dial

<SFX> (OS)
grunting

SLG

Trans

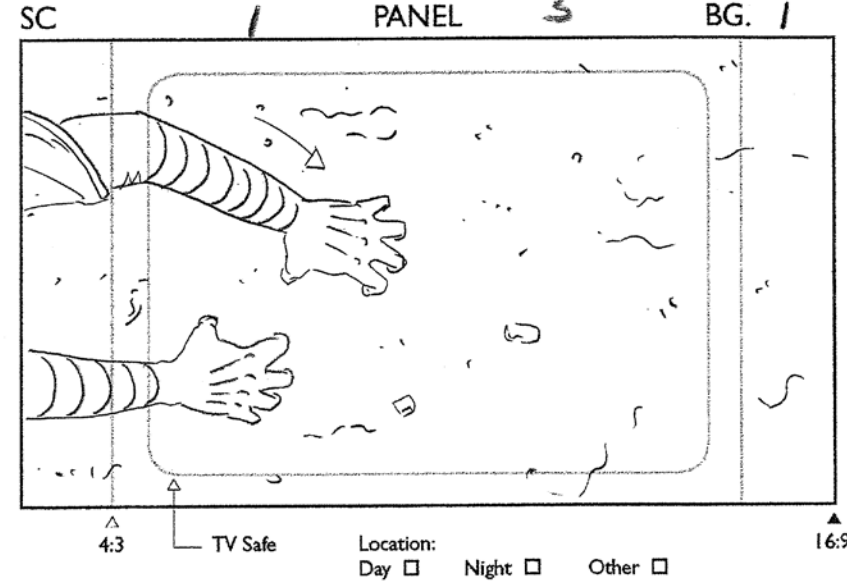

Action

Sokka's left hand
does the same

Dial

<SFX>
grunting

SLG

Trans

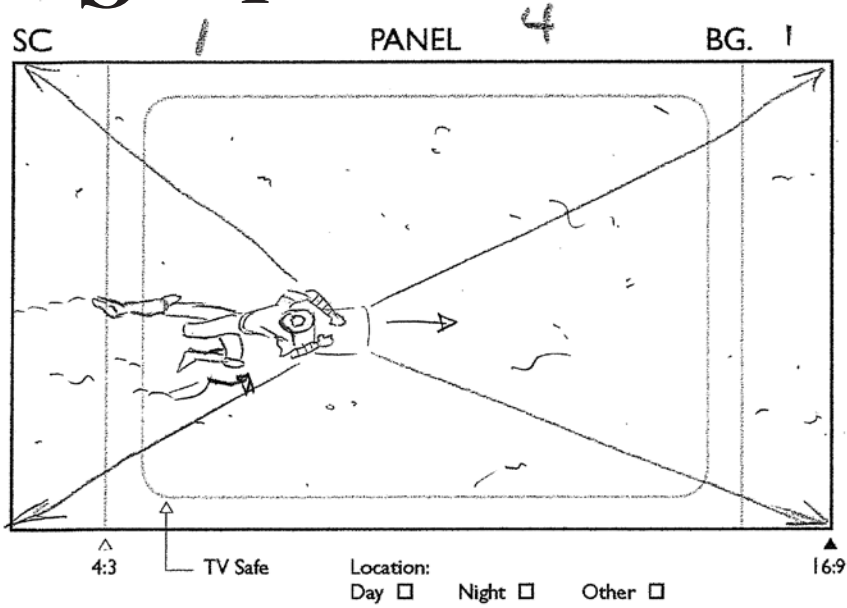

Action Pull back slowly to show Sokka crawling with a useless limp left leg, only right leg moves

Dial

SLG

Trans

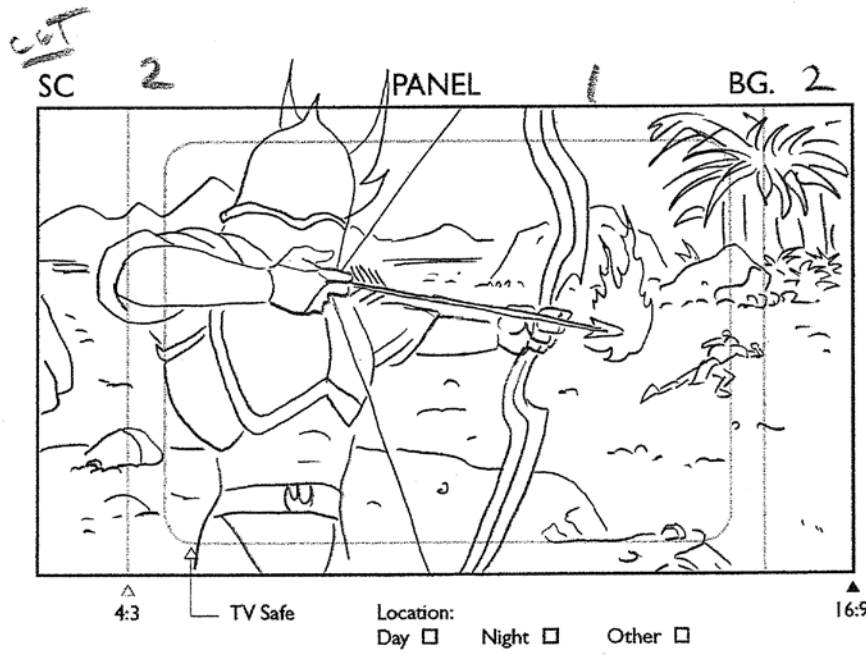

Action Archer has Sokka in his sight

Dial

SLG

Trans

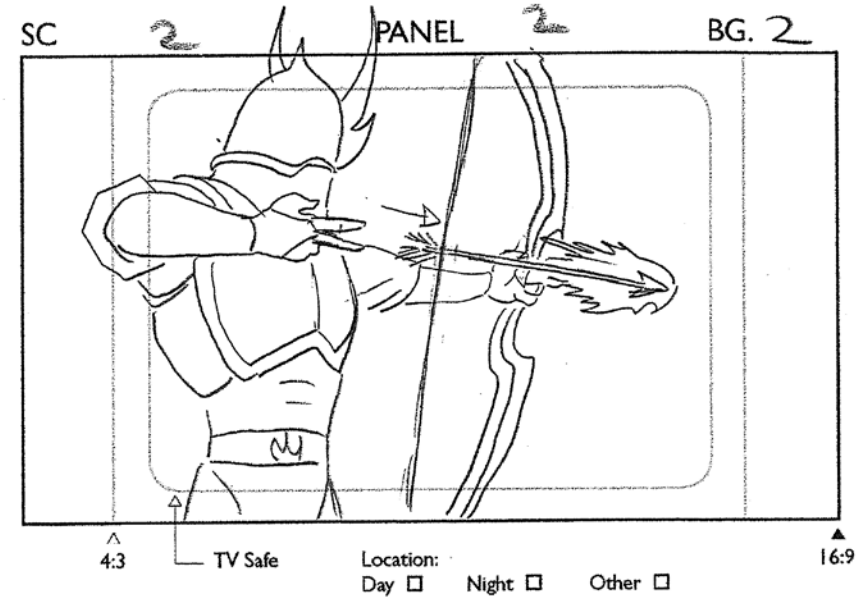

Action Archer released the arrow quickly.

Dial

SLG

Trans

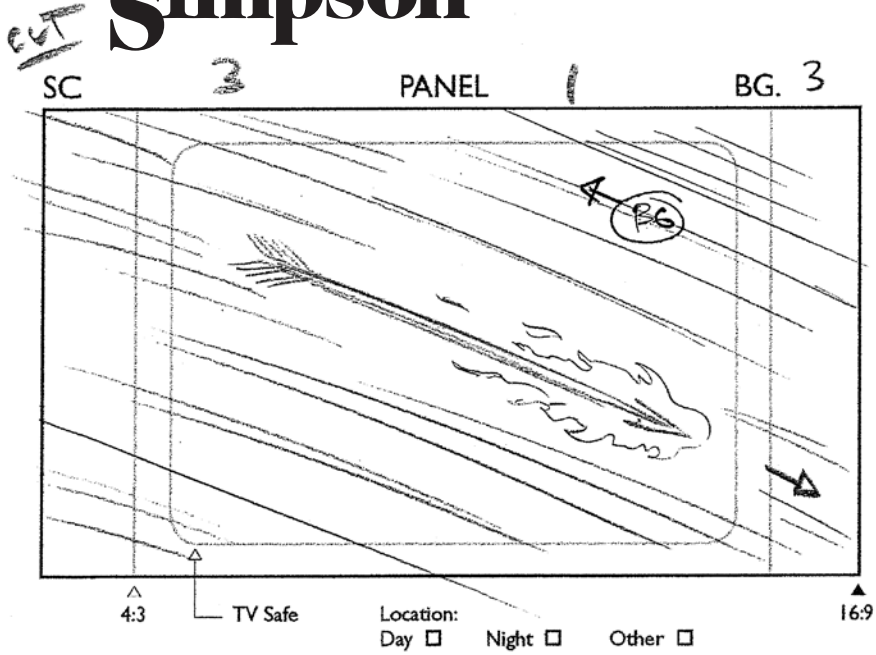

Action

speed lines
back ground

Dial

SLG

Trans

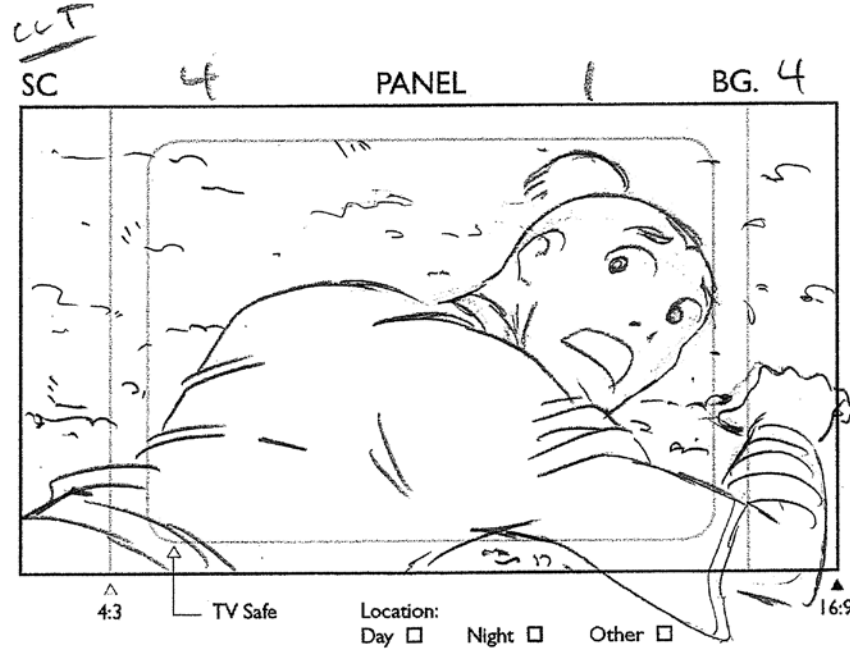

Action

Sokka sees
O.S. arrow.

Dial

SLG

Trans

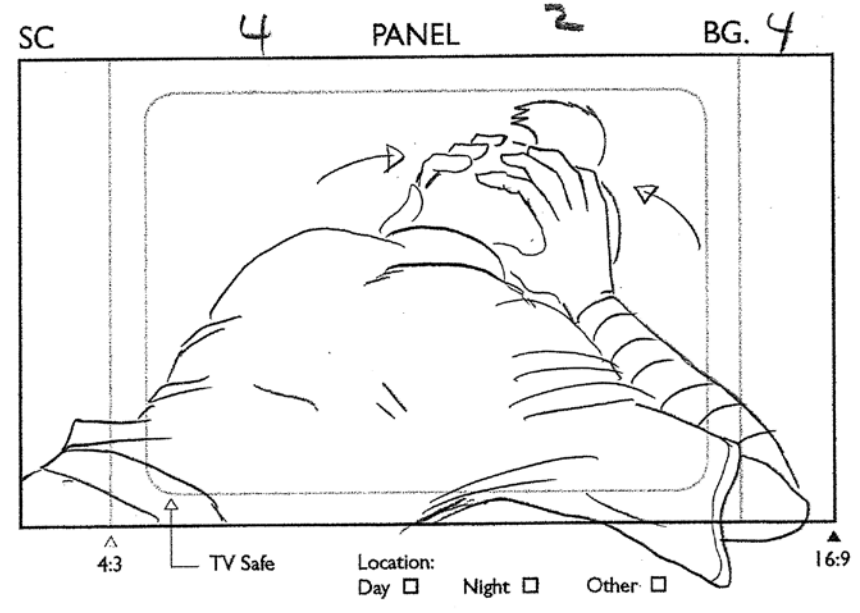

Action

Sokka braces
for + he won't. (SC) →

Dial

SLG

Trans

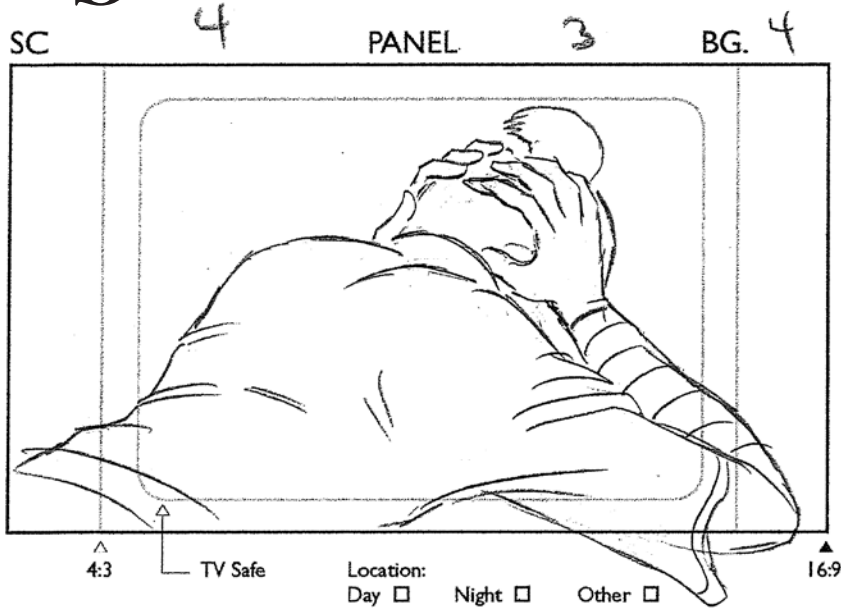

Action

Dial

SLG

Trans

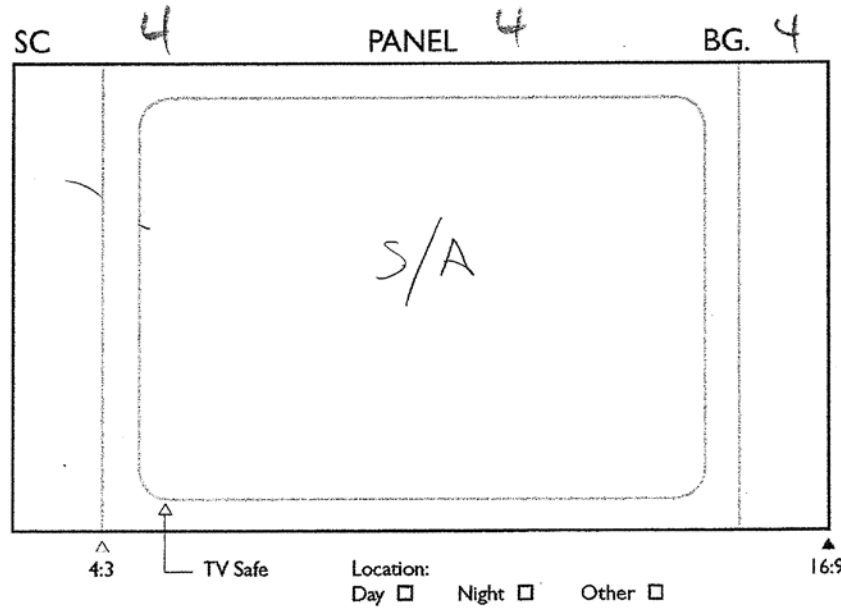

Action

Dial

SLG

Trans

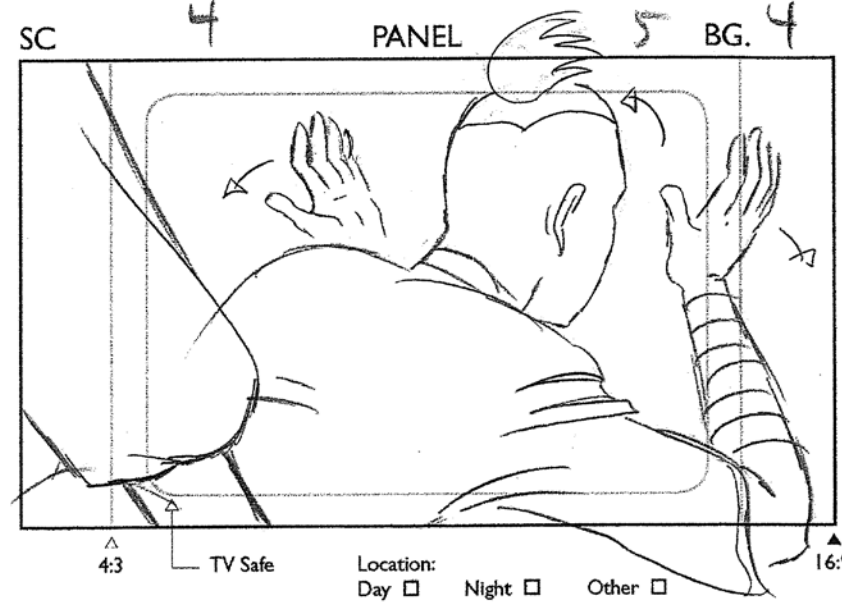

Action
Soleka head snaps up quickly at sound of voice.

Dial
AZUKA
You son of a Fire Dung Beetle!

SLG

Trans

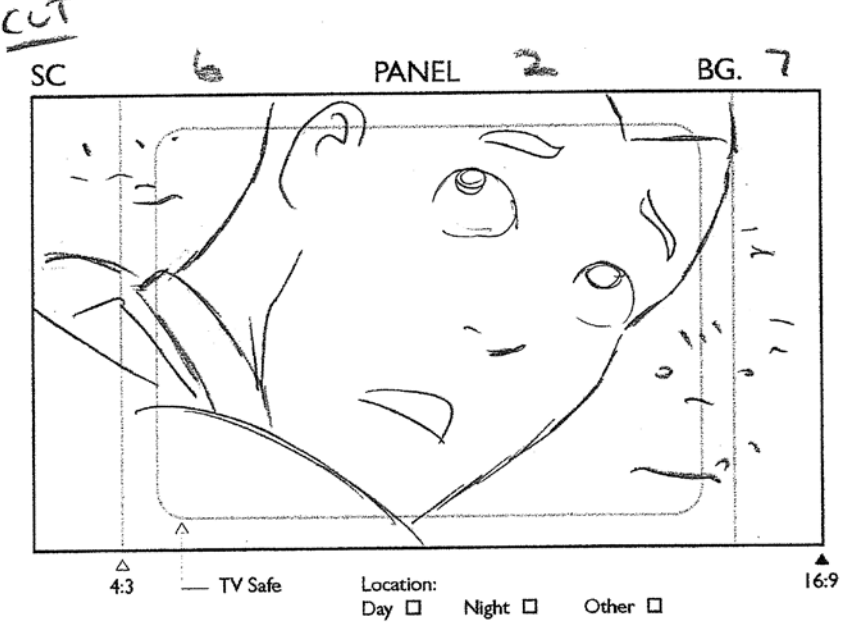
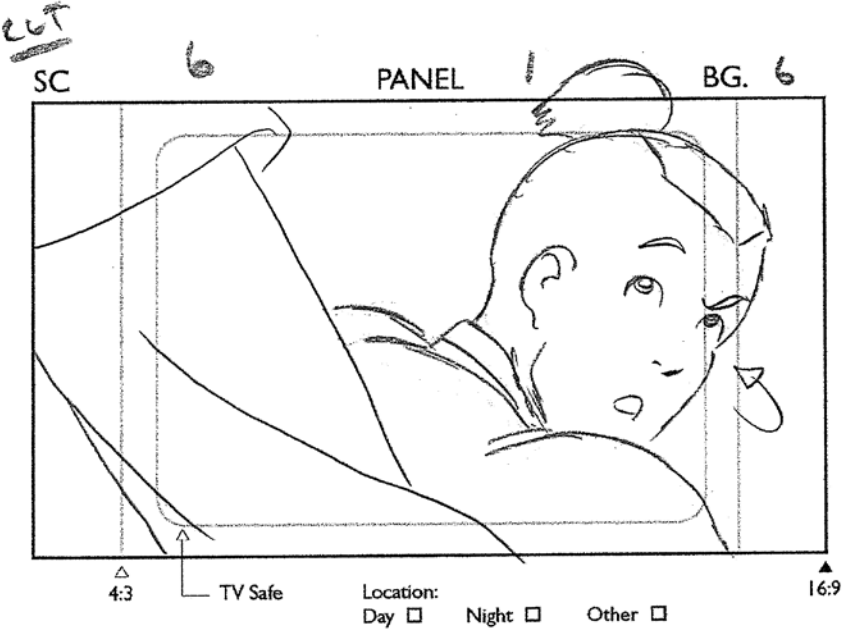
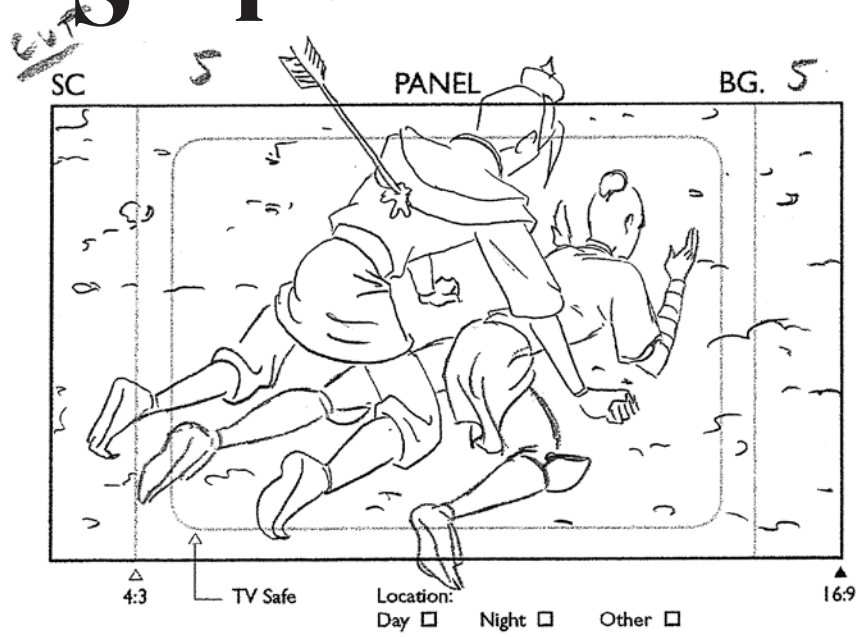

Action

Action

Sokka turns quickly

Dial

Dial

Dial

SOKKA
I'm sorry.

SLG

SLG

SLG

Trans

Trans

Trans

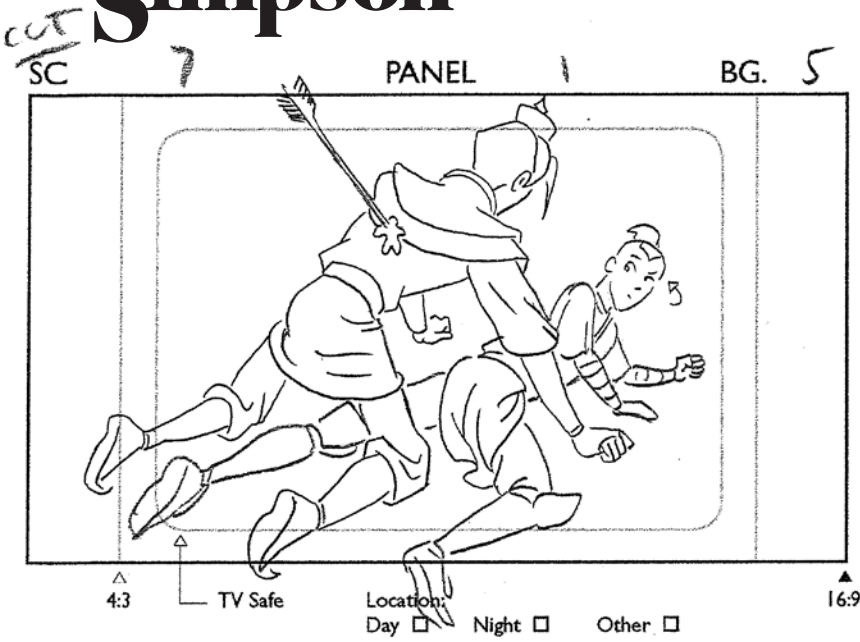

Action

Sokka begins to turn towards Azula

Dial

AZULA

with

SLG

Trans

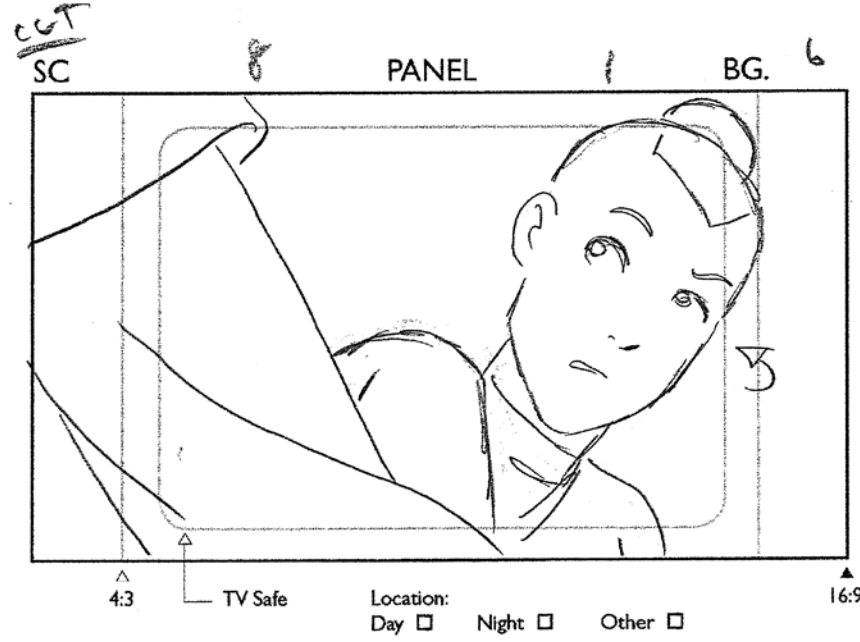

Action

Sokka continues turn

Dial

AZULA continue

is

SLG

Trans

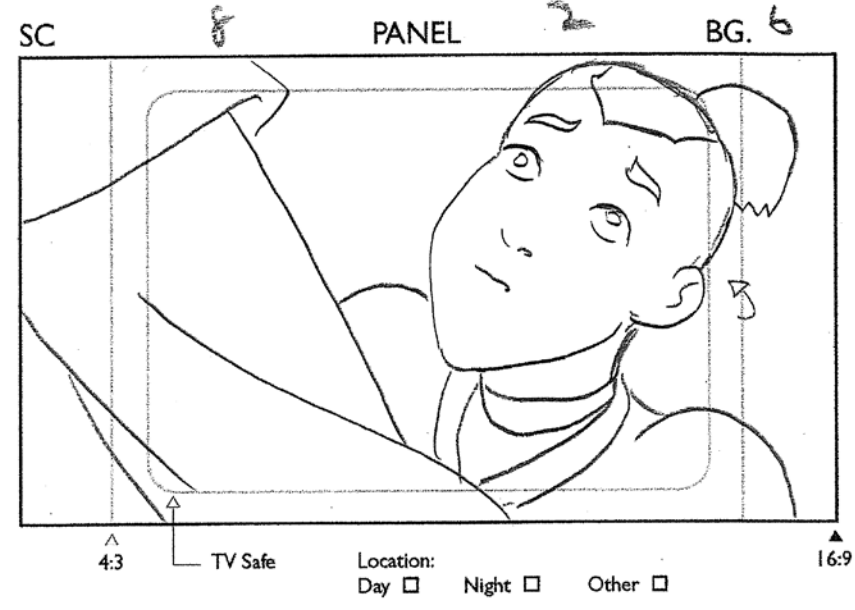

Action

Sokka completes turn.

Dial

AZULA continue

she?

SLG

Trans

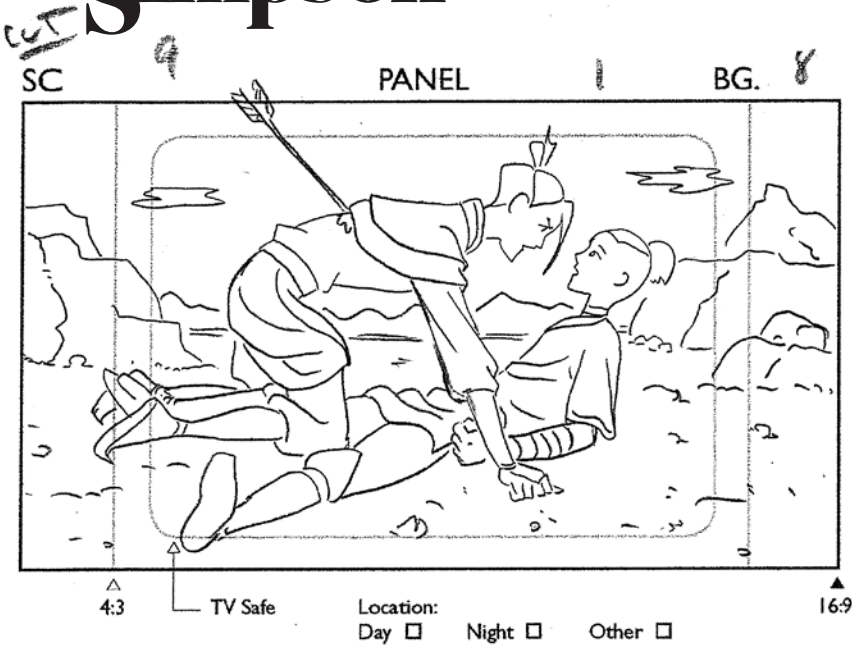

Action

Dial AZULA control

SLG

Trans

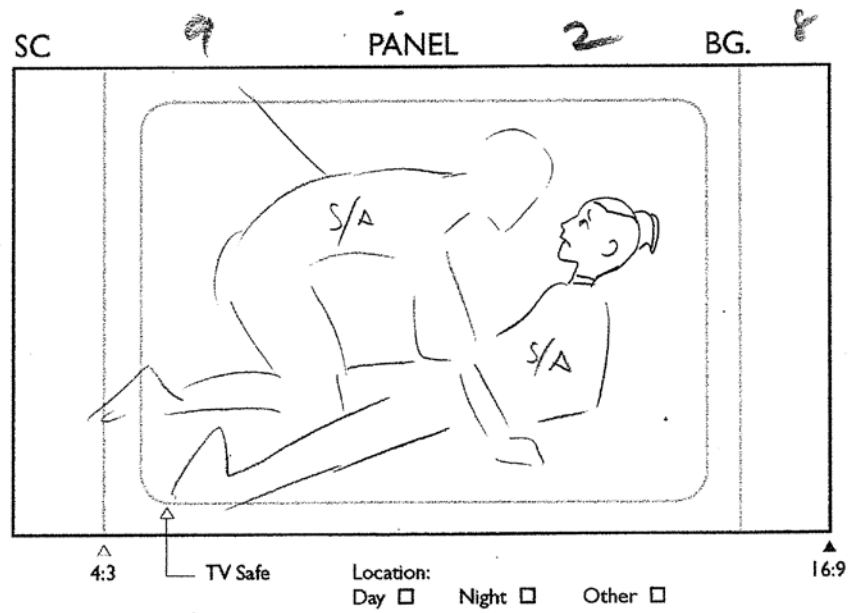

Action

Solika looks trapped

Dial AZULA control

SLG

Trans

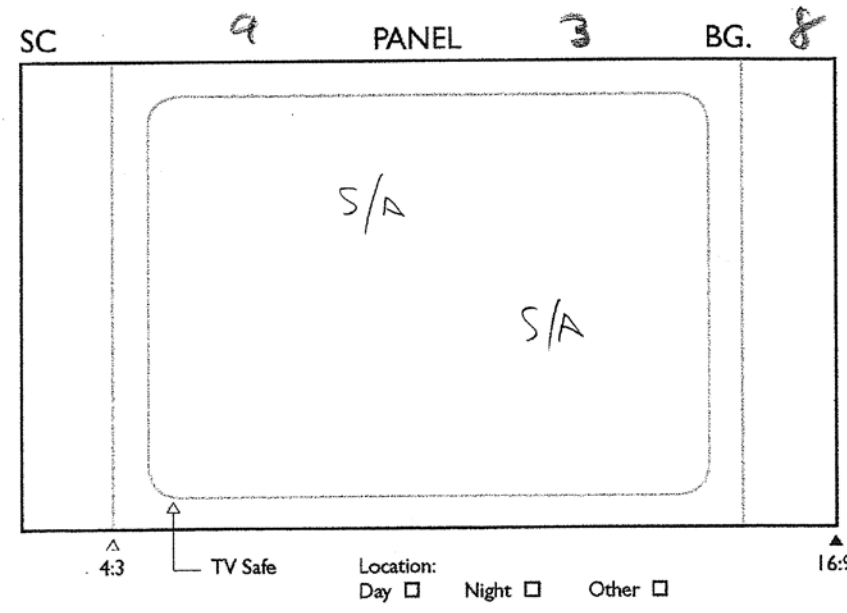

Action

Dial AZULA control

SLG

Trans

1 → want → 70

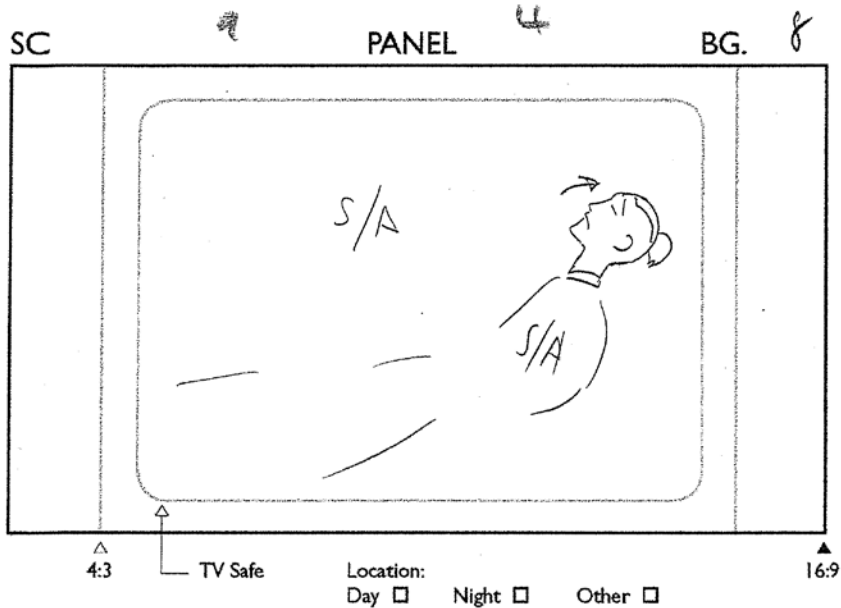

Action Sokka head reels back

Dial AZUKA cont'd

→ know →

SLG

Trans

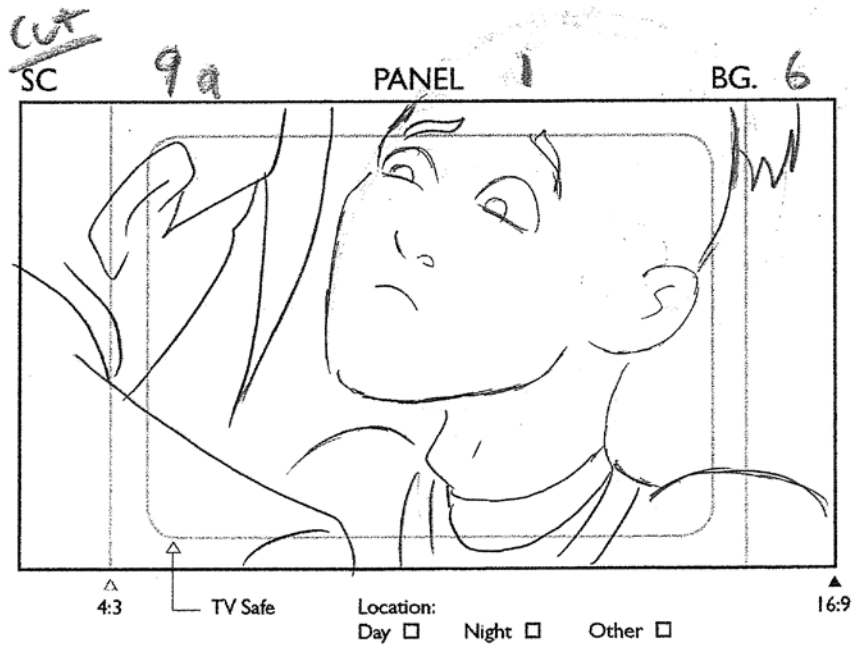

Action Sokka starts to gulp as adam's apple appears

Dial AZUKA cont'd

who →

SLG

Trans

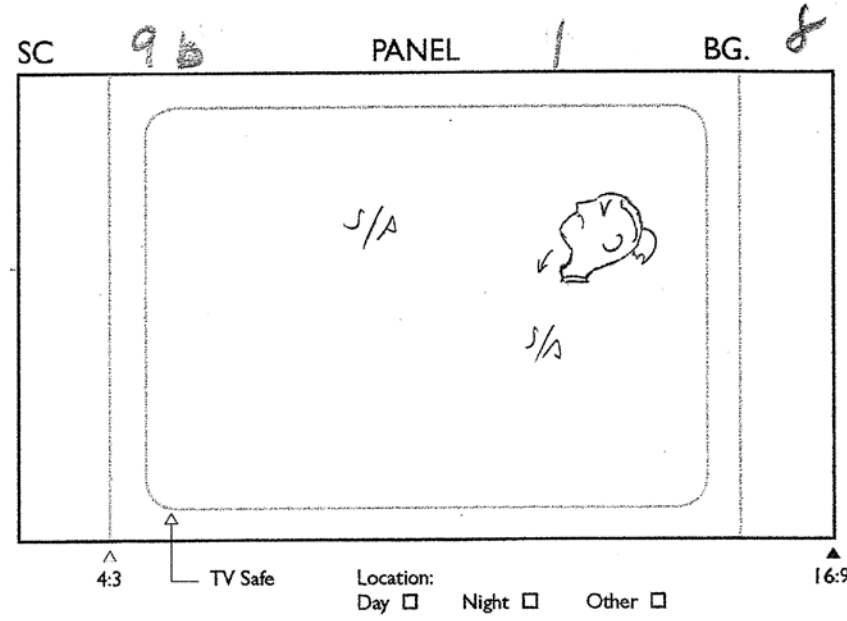

Action Adam's apple goes down as he finishes gulp.

Dial AZUKA cont'd

she is!

SLG

Trans

SC 10 PANEL 1 BG. 9

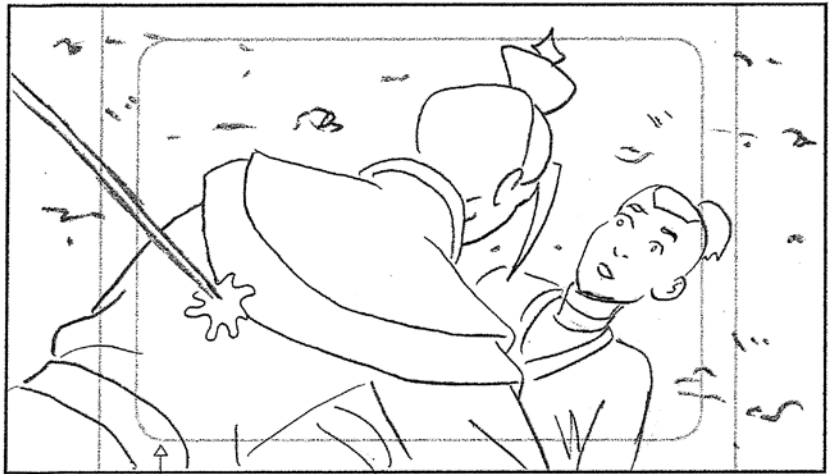

4:3 TV Safe Location: Day Night Other 16:9

Action

Dial

SOKKA

It doesn't matter

SLG

Trans

SC 10 PANEL 2 BG. 9



4:3 TV Safe Location: Day Night Other 16:9

Action

Sokka slowly raises his hand

Dial

SOKKA cont'd

I want

SLG

Trans

SC 10 PANEL 3 BG. 9



4:3 TV Safe Location: Day Night Other 16:9

Action

and quickly slaps her!

Dial

SOKKA cont'd

a divorce!

SLG

Trans

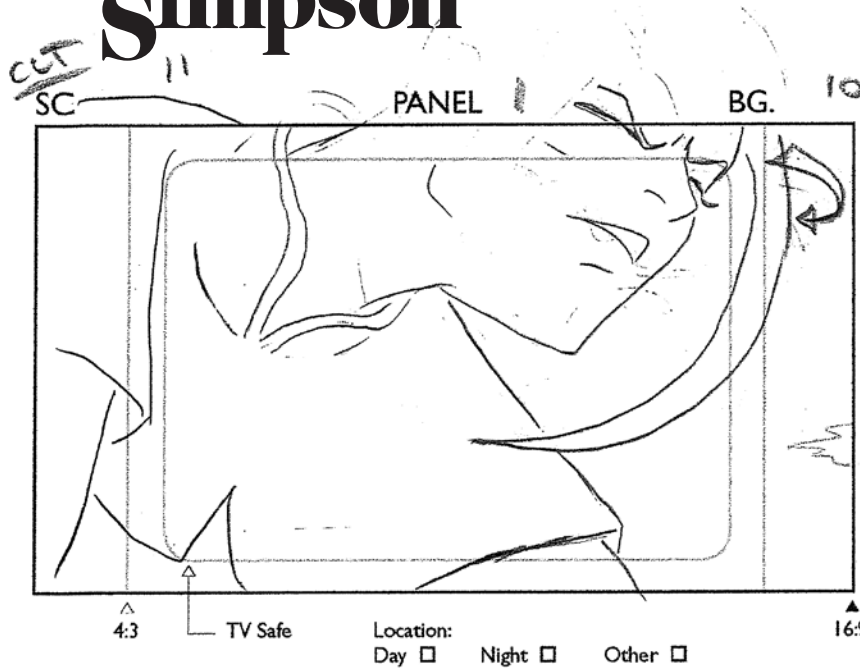

Action

Hook-up head turning from slap in scene 10

Dial

AZULA
A divorce? →

SLG

Trans

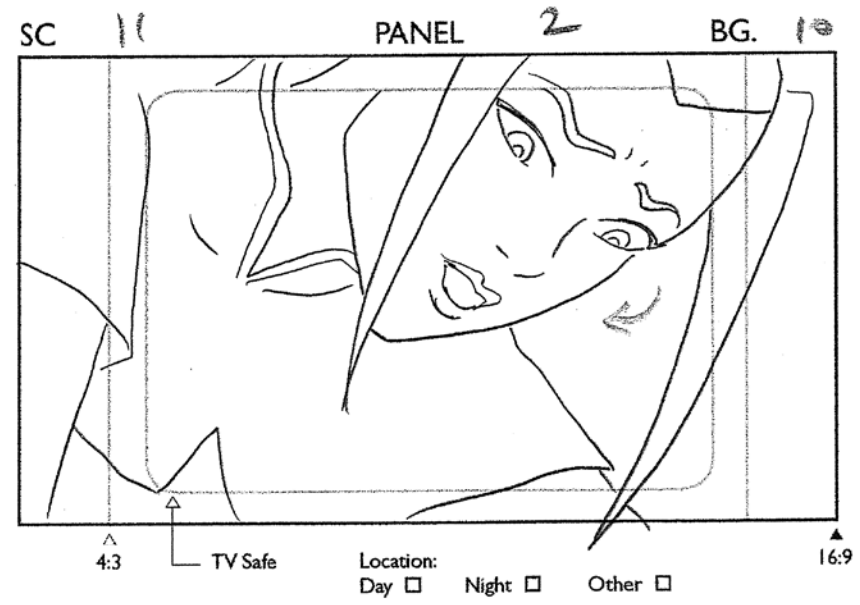

Action

Dial

AZULA control
so you →

SLG

Trans

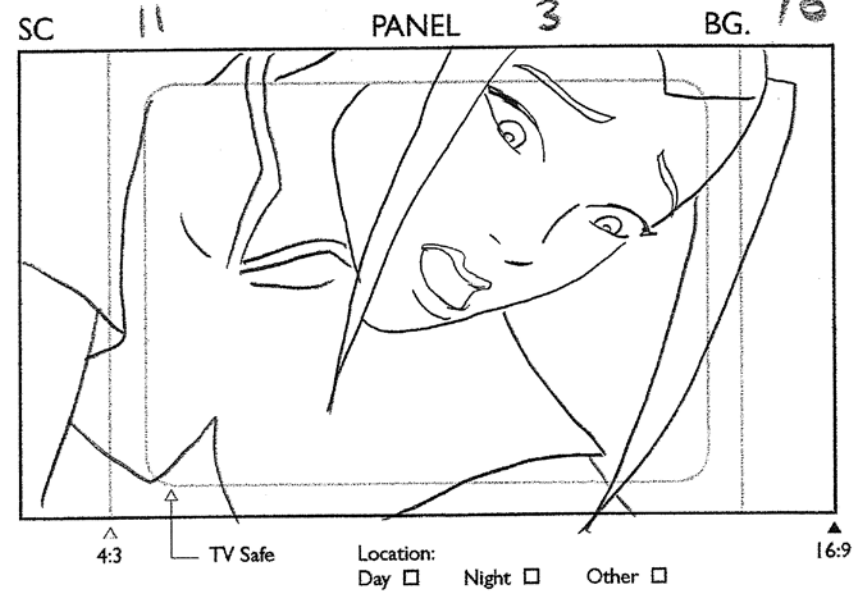

Action

Dial

AZULA control
can marry →

SLG

Trans

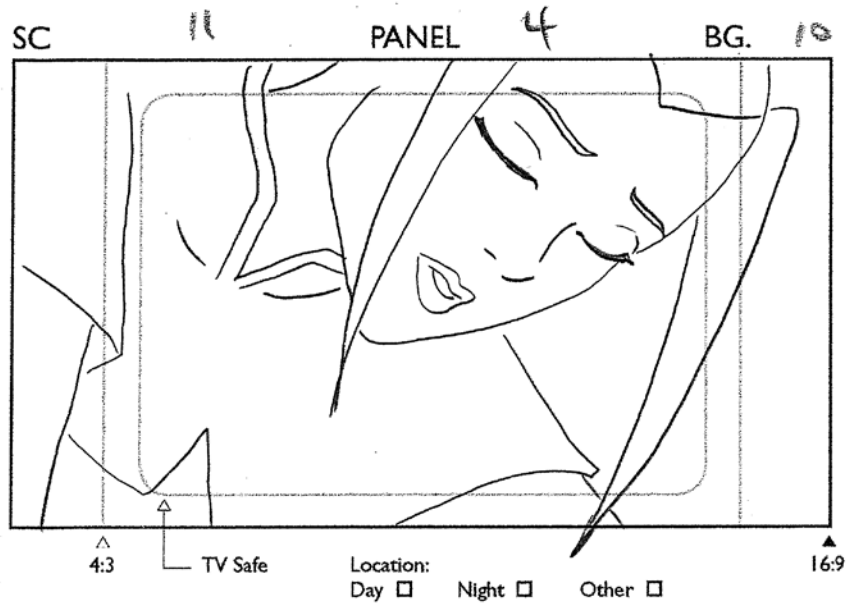

Action

Dial

AZULA cont'd

→ her

SLG

Trans

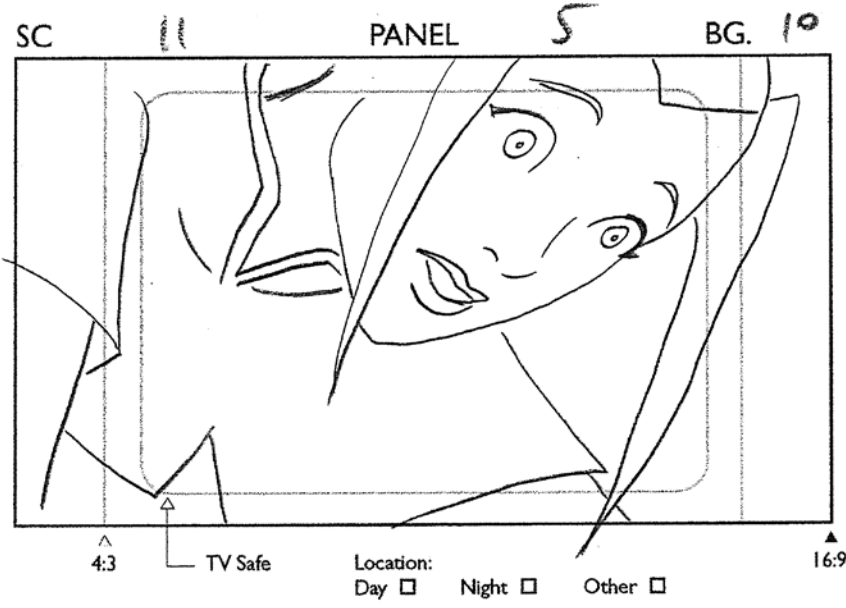

Action

Dial

AZULA cont'd

→ and

SLG

Trans

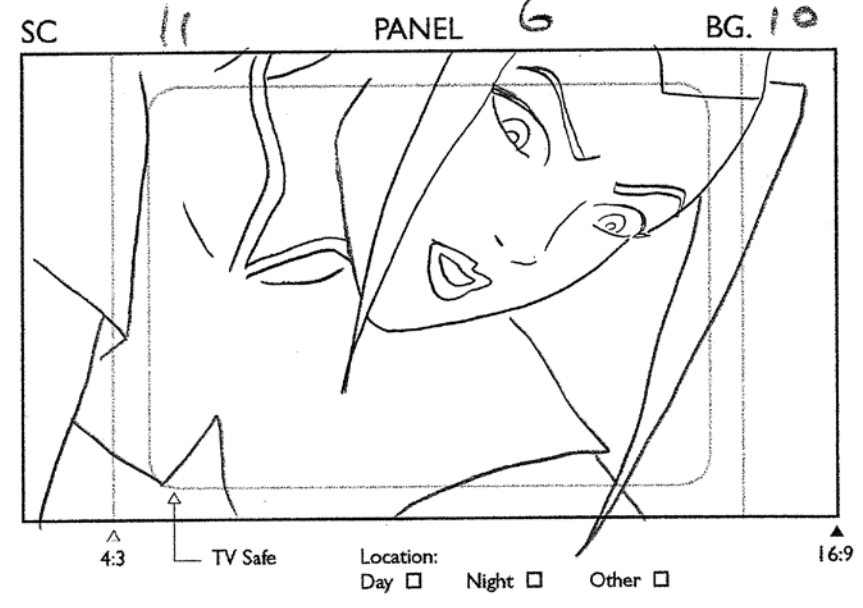

Action

Dial

AZULA cont'd

→ give her

SLG

Trans

SC 11 PANEL 7 BG. 10

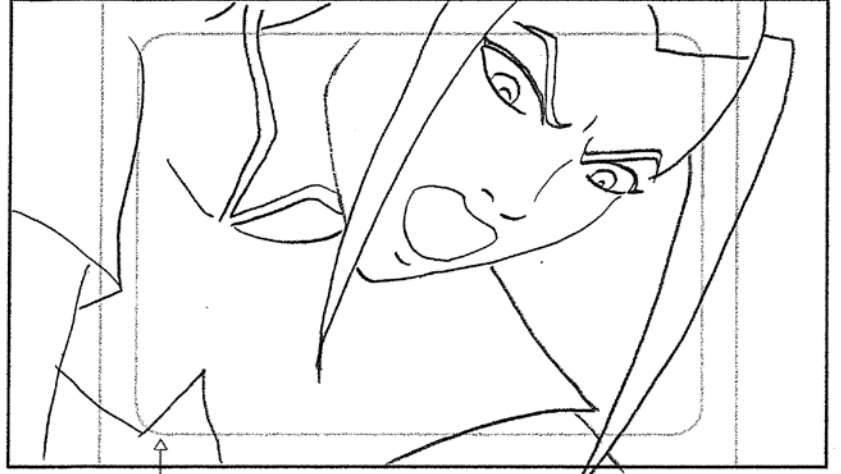

4:3 TV Safe Location: Day Night Other 16:9

Action

Dial

AZULA could
→ the discount?

SLG

Trans

CUT
SC 12 PANEL 1 BG. 9



4:3 TV Safe Location: Day Night Other 16:9

Action

Dial

SO ICKA
Yes, that's
right

SLG

Trans

CUT
SC 13 PANEL 1 BG. 10



4:3 TV Safe Location: Day Night Other 16:9

Action

Tears start to well up
in Azula's eyes

Dial

AZULA
what →

SLG

Trans

SC 13 PANEL 2 BG. 10

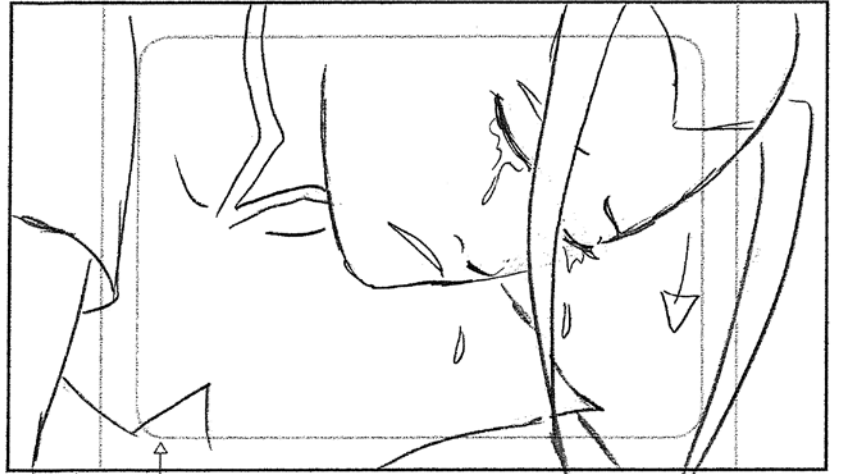

4:3 TV Safe Location: Day Night Other 16:9

Action

Azula cries and head drop/ downward

Dial

AZULA cont'd

→ happened to us Sokka?

SLG

Trans

^{cut} SC 14 PANEL 1 BG. 9



4:3 TV Safe Location: Day Night Other 16:9

Action

Dial

SOKKA

I'll tell you

SLG

Trans

SC 14 PANEL 2 BG. 9

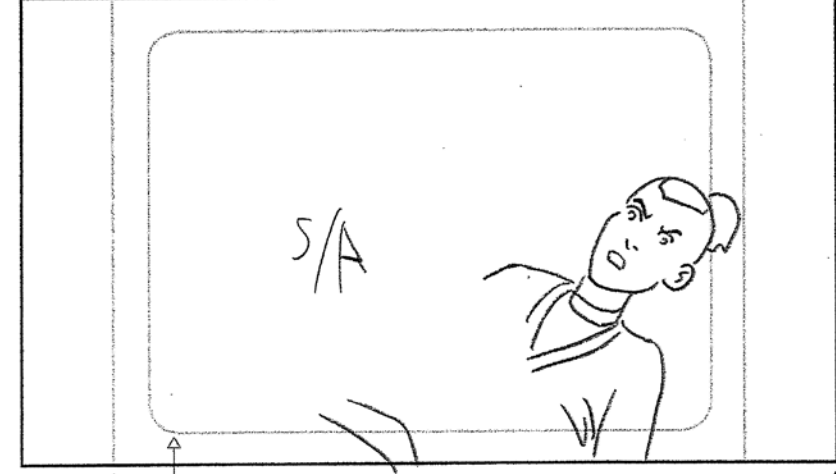

4:3 TV Safe Location: Day Night Other 16:9

Action

Dial

SOKKA cont'd

→ what happened.

SLG

Trans

SC 14 PANEL 3 BG. 9

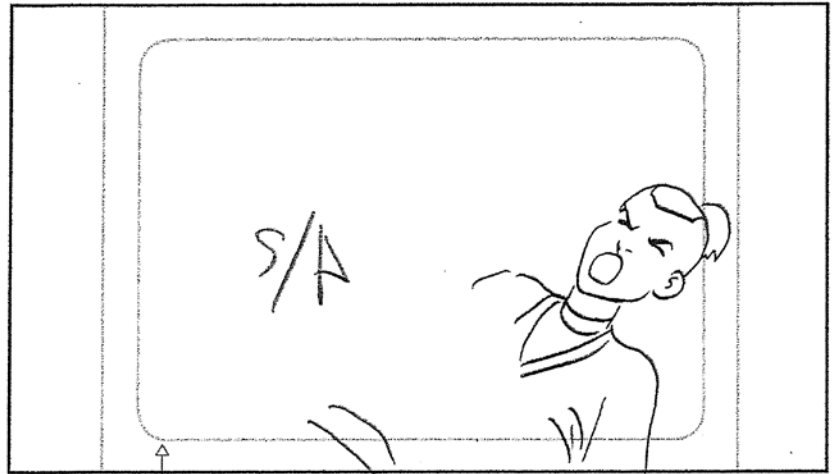

4:3 TV Safe Location: Day Night Other 16:9

Action

Dial SOKKA cont'd

→ We got married!

SLG

Trans

^{cut} SC 15 PANEL 1 BG. 10



4:3 TV Safe Location: Day Night Other 16:9

Action

Dial AZULA

I'm sorry.

SLG

Trans

SC 15 PANEL 2 BG. 10



4:3 TV Safe Location: Day Night Other 16:9

Action

Dial AZULA cont'd

→ This is my fault. →

SLG

Trans

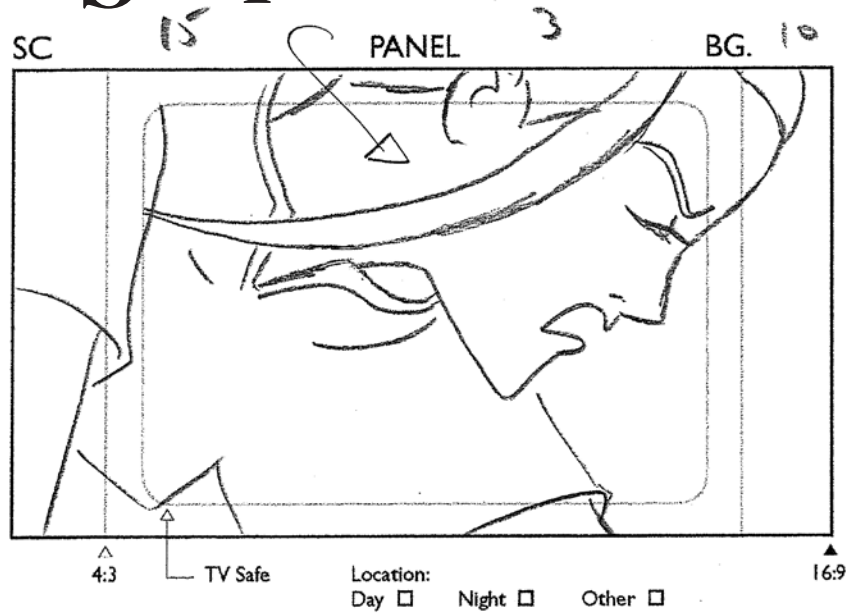

Action

Azula quickly turns away

Dial

AZULA CONT'D
→ I pushed it on you.

SLG

Trans

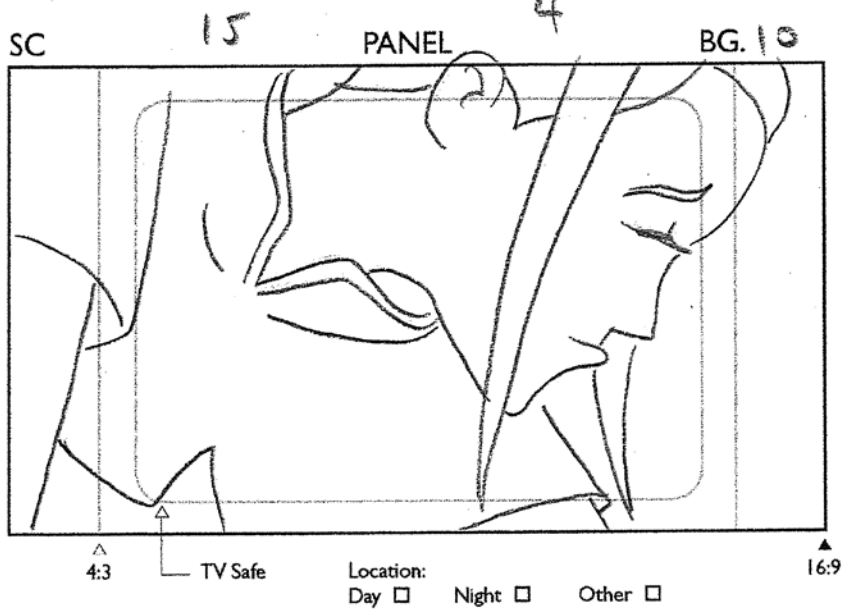

Action

Dial

SLG

Trans

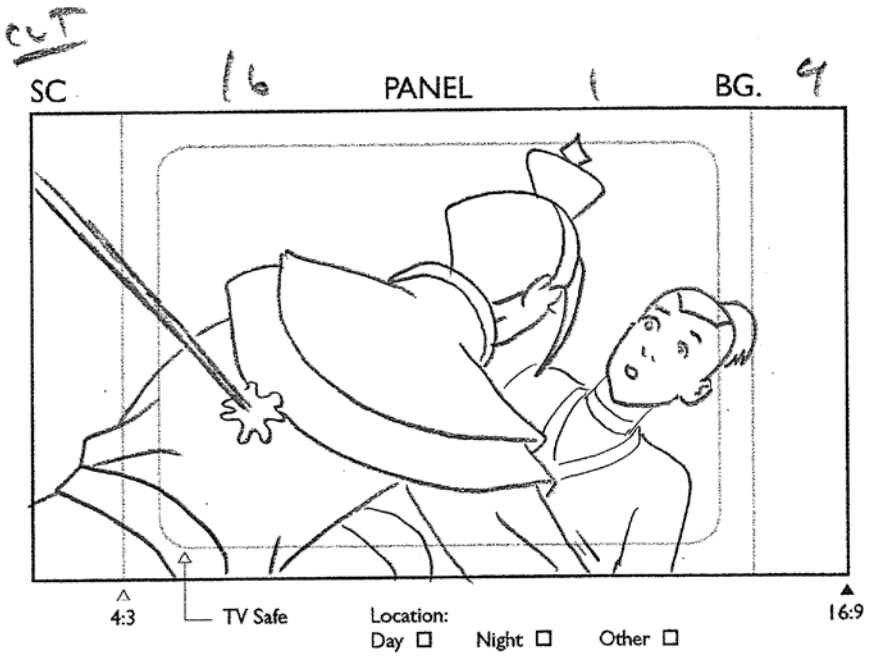

Action

Dial

SOKKA
NO.

SLG

Trans

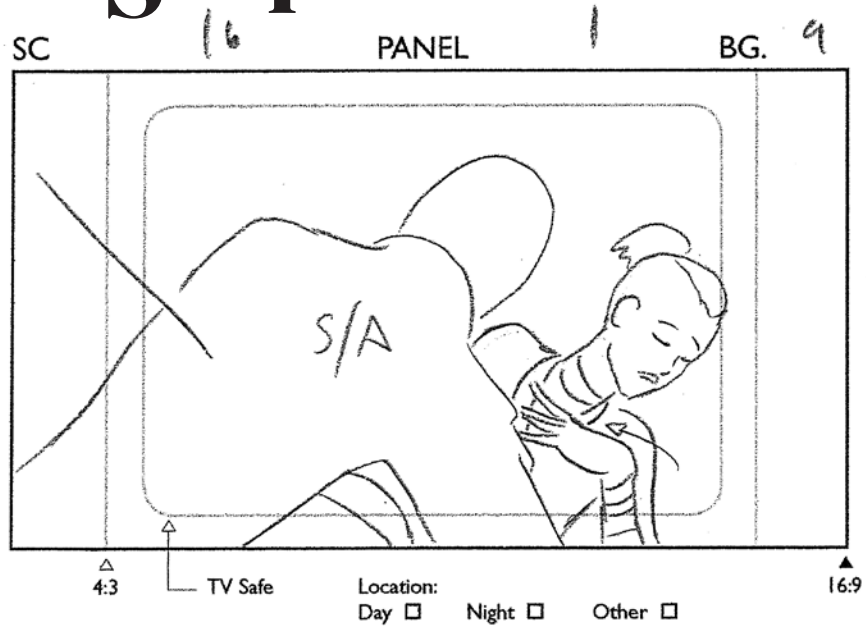

Action
Sokka raises hand to his chest quickly

Dial
Sokka cont'd
→ I just

SLG
Trans

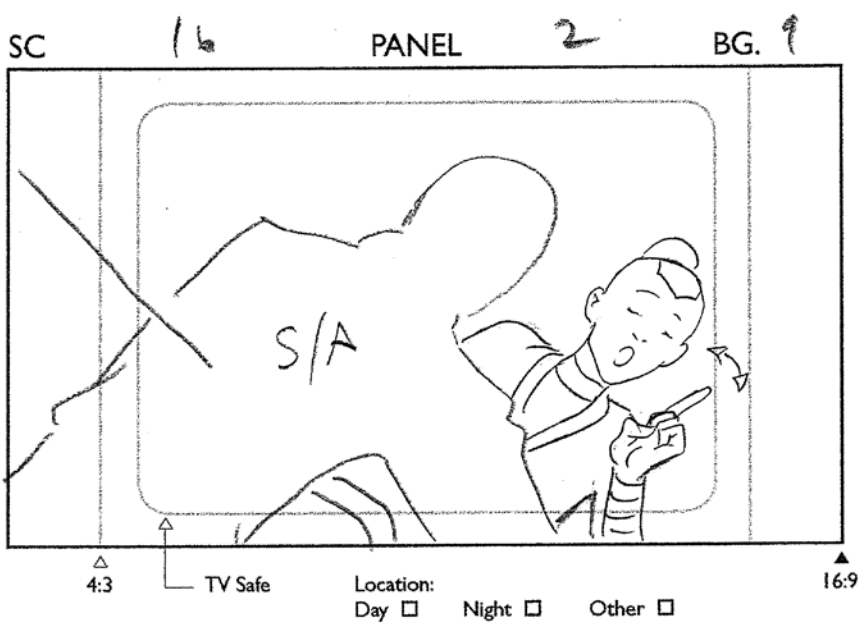

Action
Sokka waves index finger back + forth

Dial
Sokka cont'd
→ wasn't ready

SLG
Trans

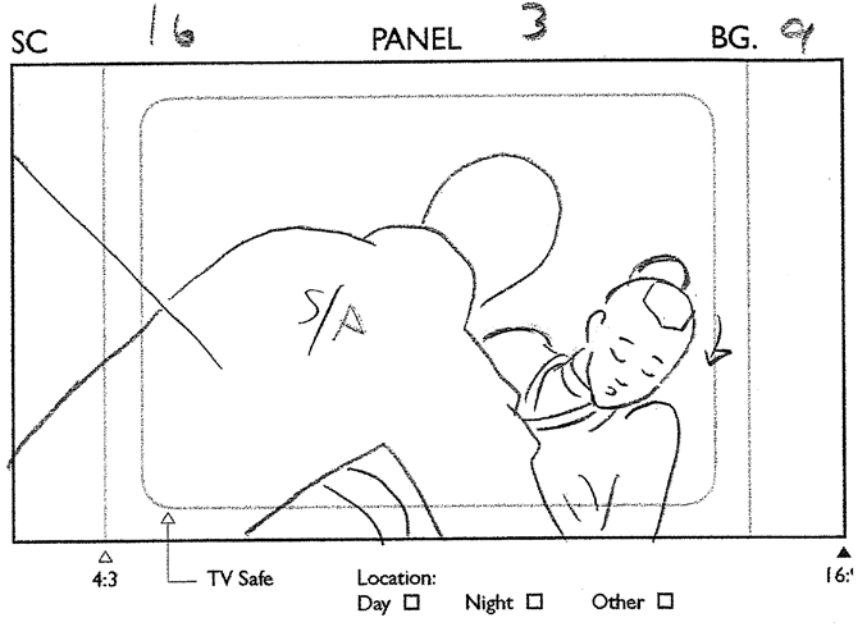

Action
Sokka drops head

Dial
Sokka cont'd
→ for the

SLG
Trans

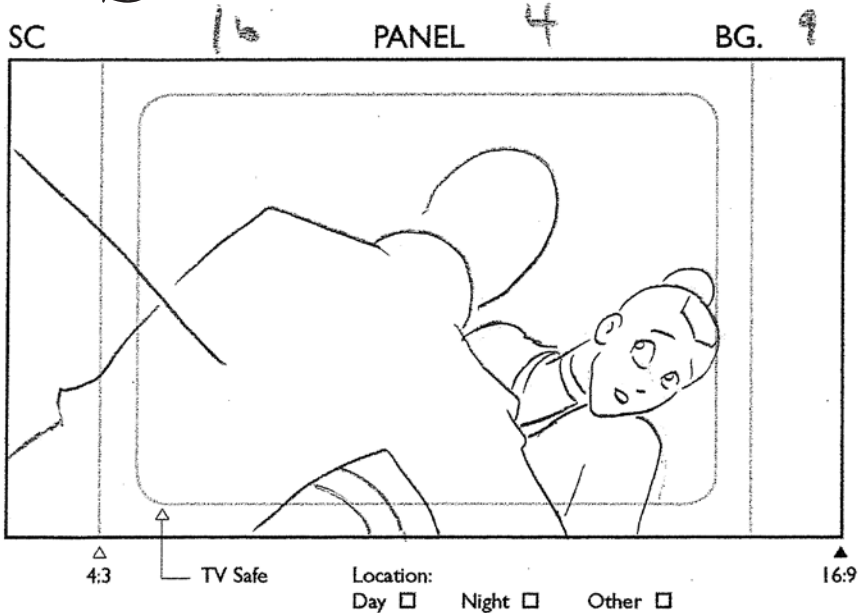

Action

Dial

SOLKA cont'd
→ responsibility

SLG

Trans

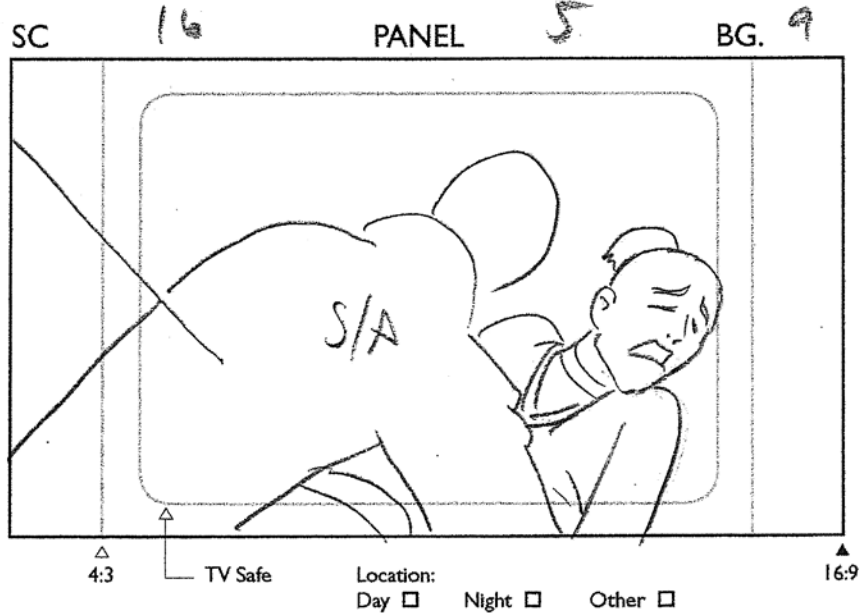

Action

Dial

SOLKA cont'd
→ of a pretend marriage.

SLG

Trans

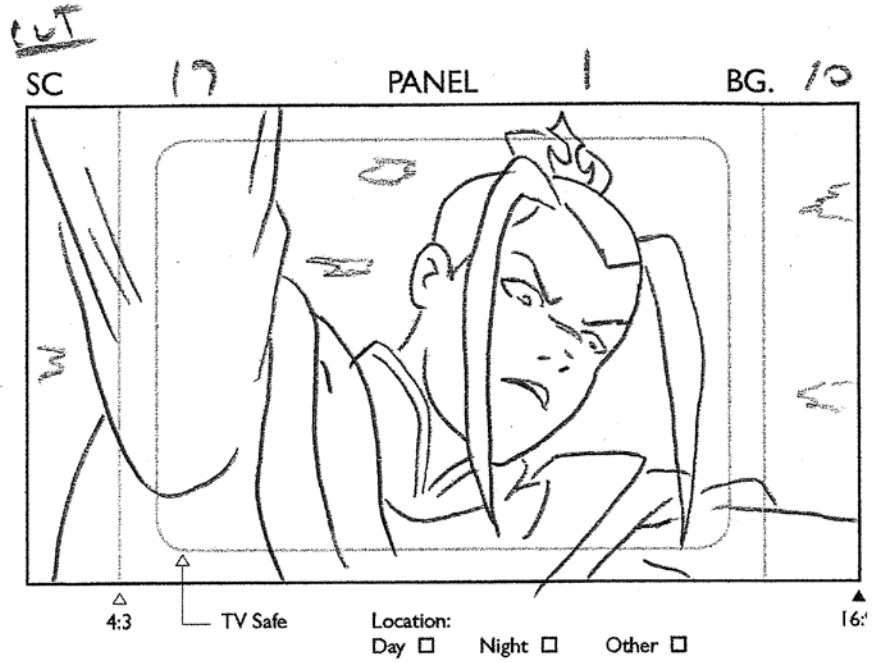

Action

Dial

AZULA
Goodbye Solka. →

SLG

Trans

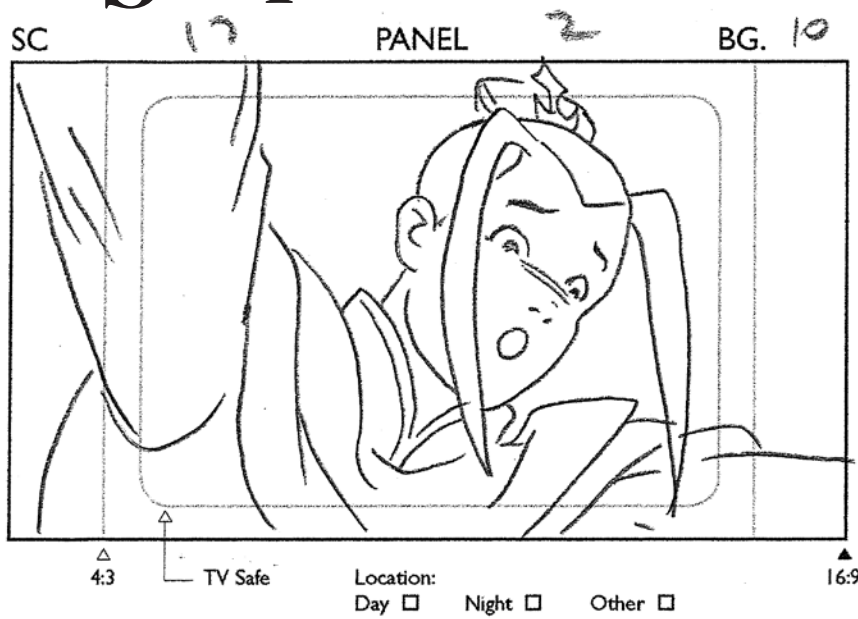

Action

Dial

AZULA cont'd

→ oh →

SLG

Trans

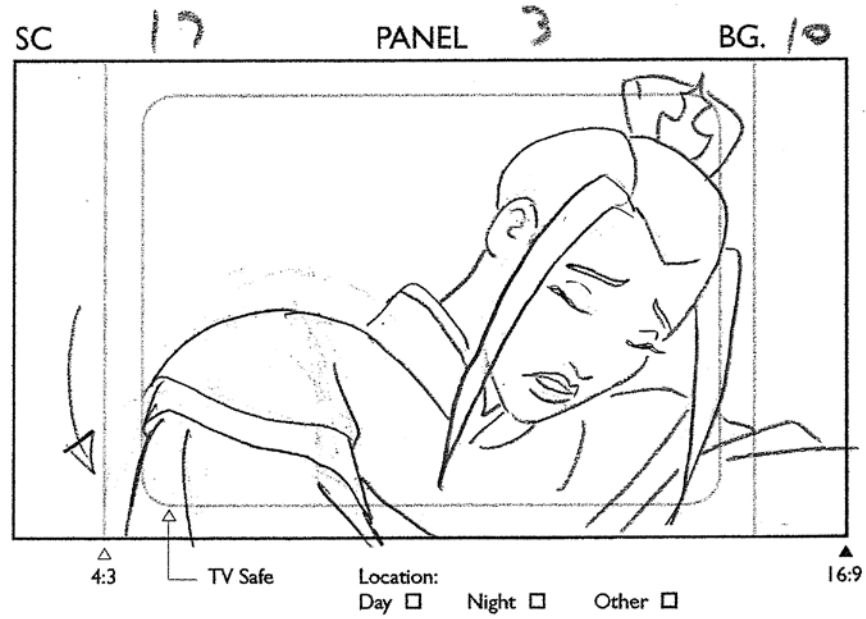

Action

Azula reaches into her tail o.s.

Dial

AZULA cont'd

I forgot. →

SLG

Trans

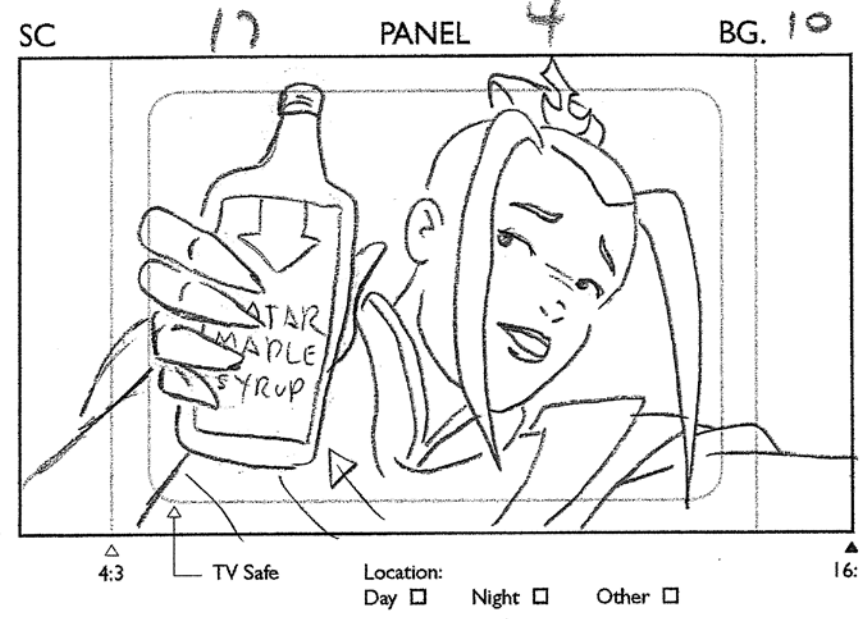

Action

Azula pulls bottle out of tunic from o.s.

Dial

AZULA cont'd

This is your maple syrup.

SLG

Trans

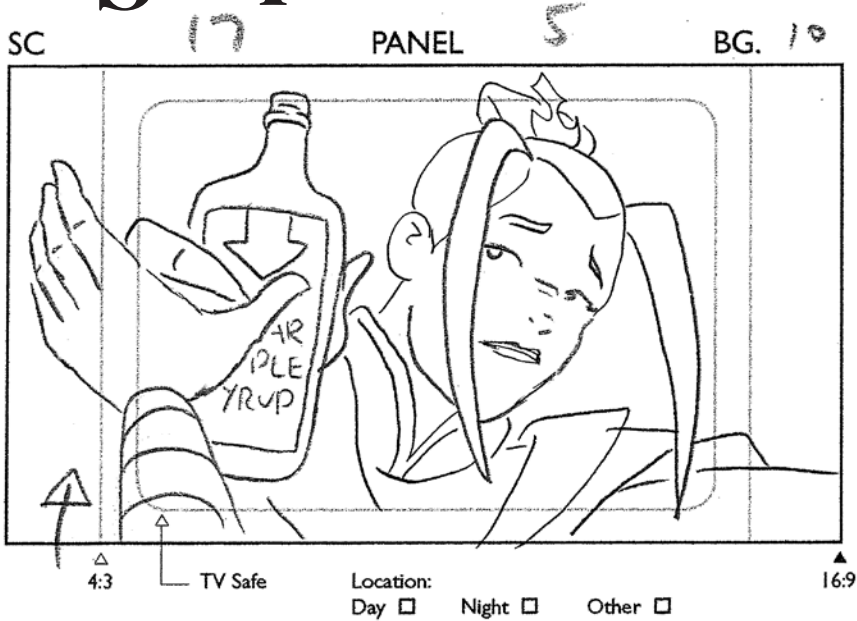

Action
Sokka reaches for her hand from O.S.

Dial
SOKKA (O.S.)
That's alright,

SLG
Trans

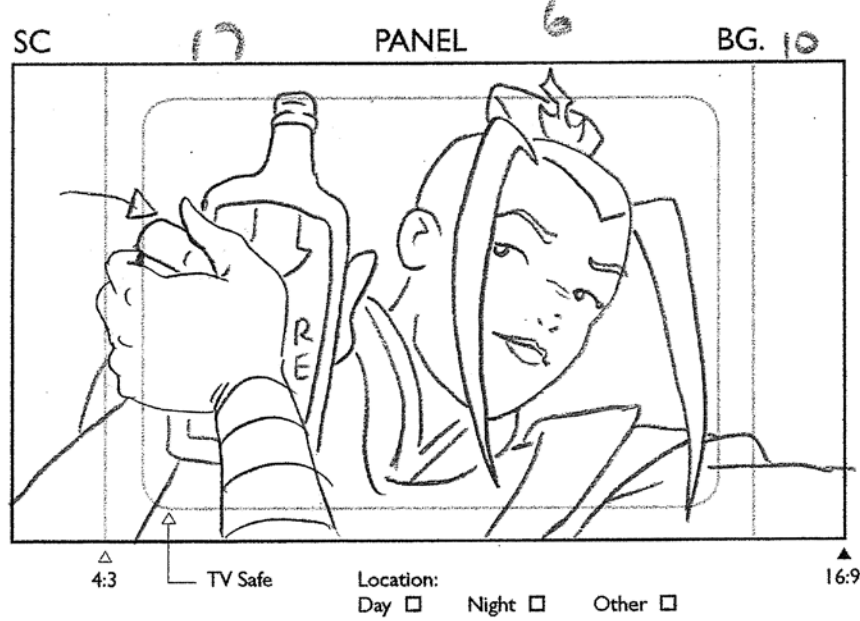

Action
Sokka pushes her hand down...

Dial
SOKKA (O.S.) cont'd
I want

SLG
Trans

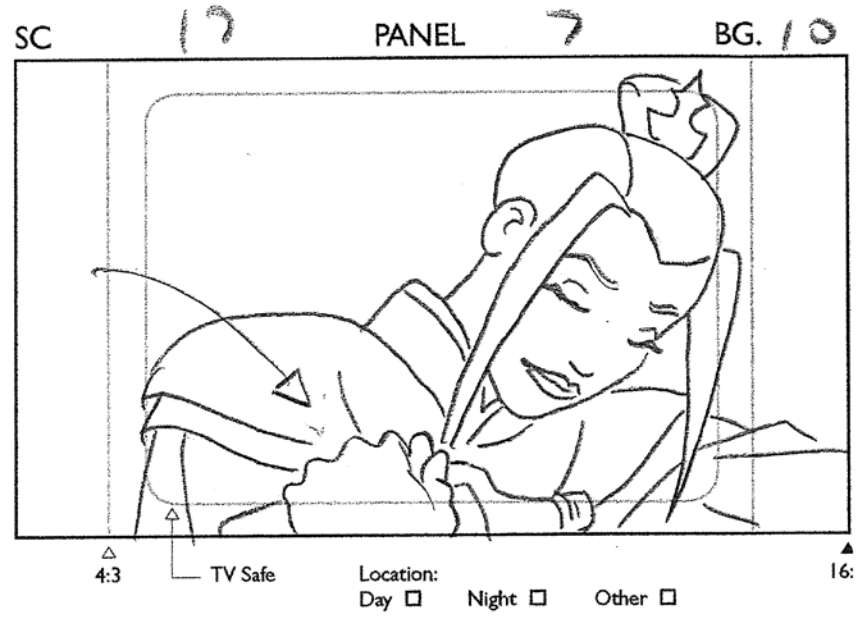

Action
to put bottle back in her Tonic O.S.

Dial
SOKKA (O.S.) cont'd
you to have it.

SLG
Trans

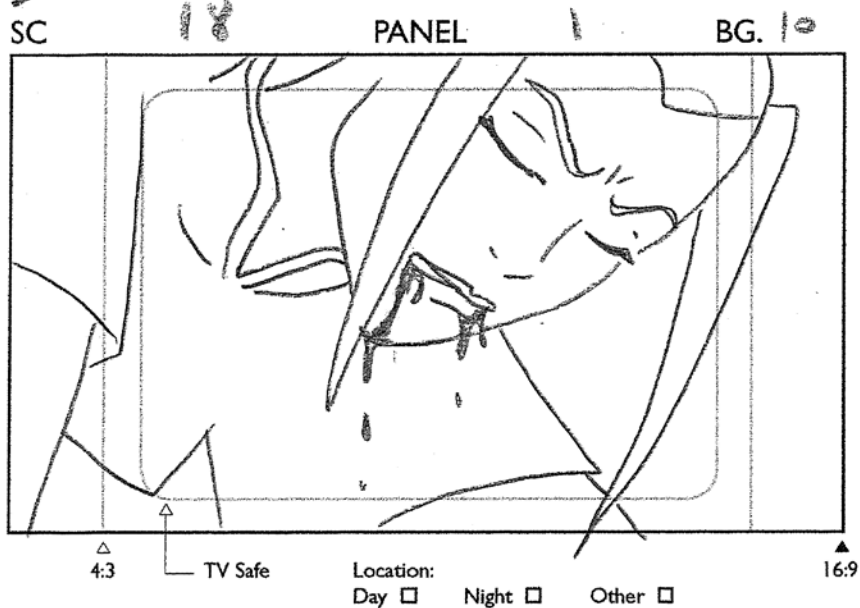

Action
Azula begins bleeding from her mouth

Dial
AZULA
OK, thanks

SLG

Trans

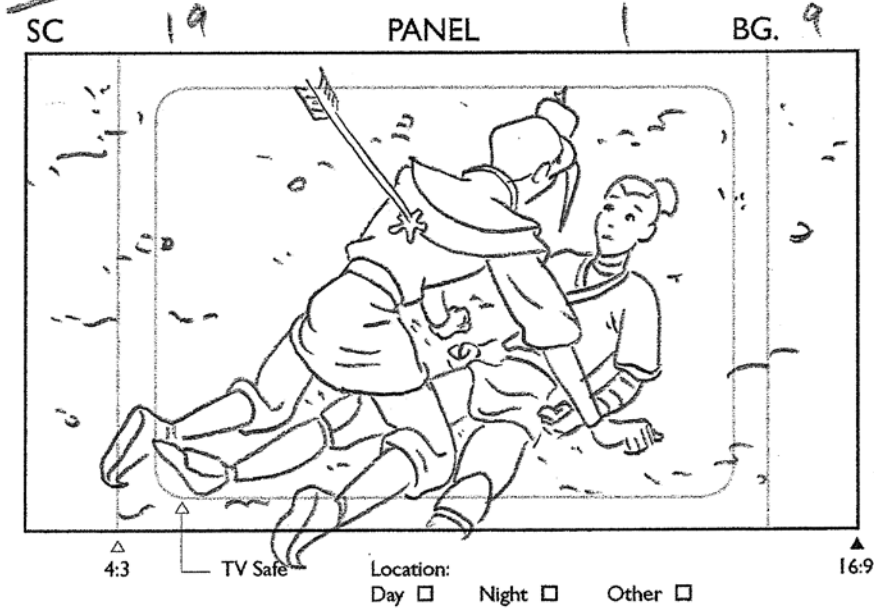

Action
Azula struggles to stay up right.

Dial
AZULA cont'd
We'll always

SLG

Trans

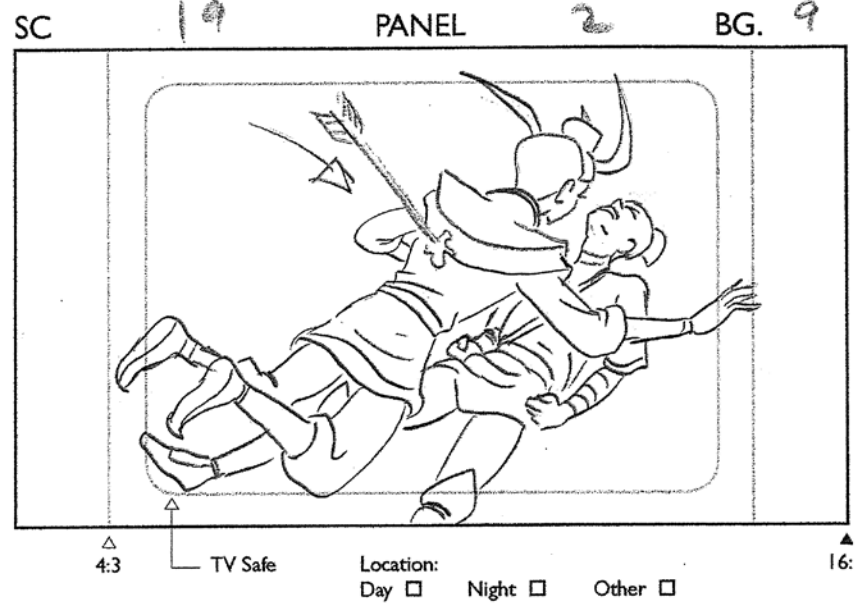

Action
Azula collapses!

Dial
AZULA cont'd
have pancakes.

SLG

Trans

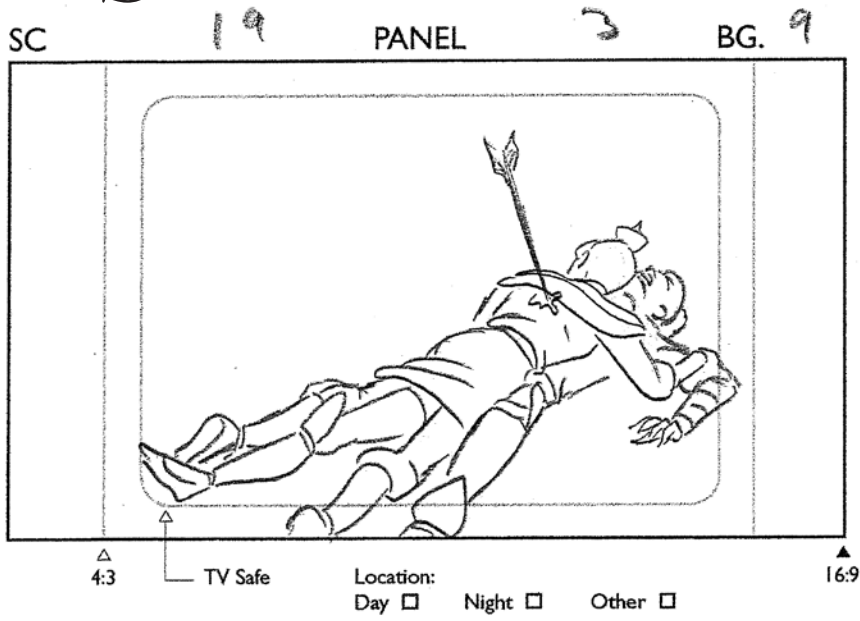

Action

Dial AZUKA cont'd
Bye sokka.

SLG

Trans

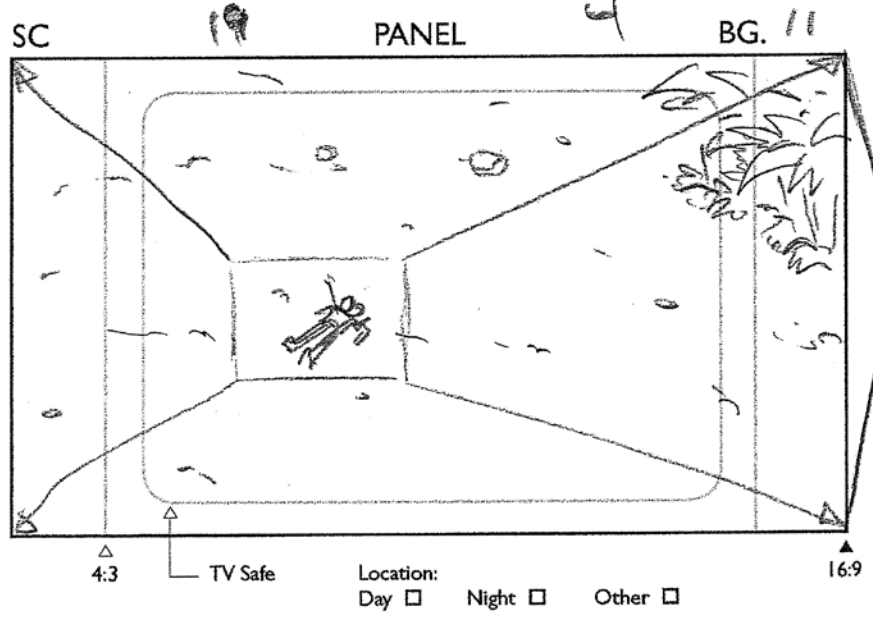

Action

Dial

SLG

Trans

Pull out slowly,

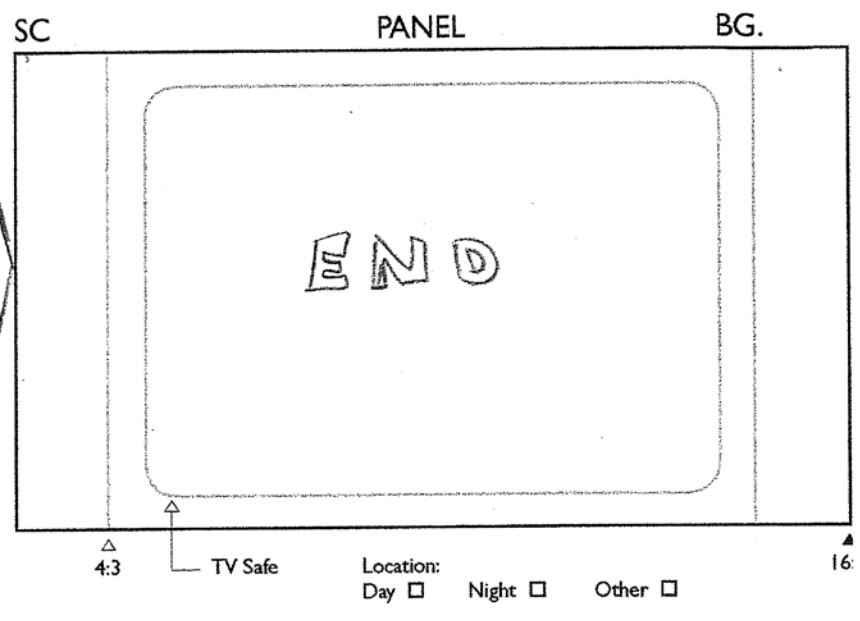

Action

Dial

SLG

Trans

Fade to black

SC 1 PANEL A BG. 1

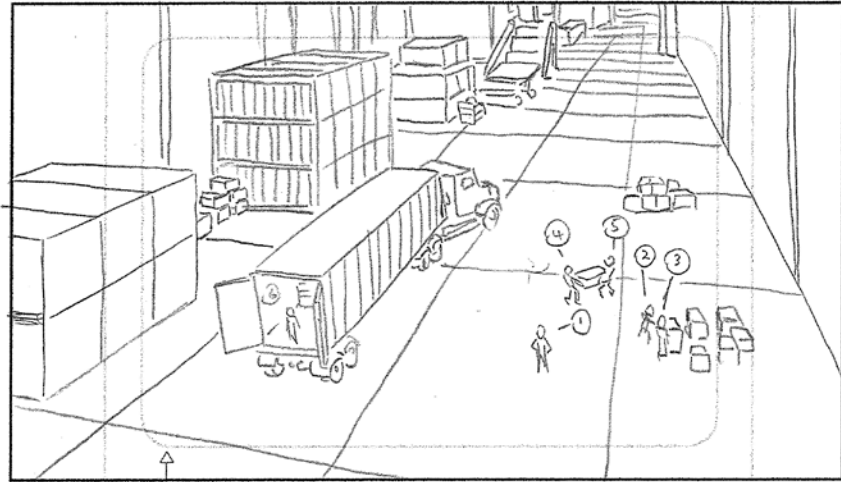

4:3 TV Safe Location: Day Night Other 16:9

Action

6 Thugs load a truck with crates

Dial

SLG

Trans

CUT
SC 2 PANEL A BG. 2

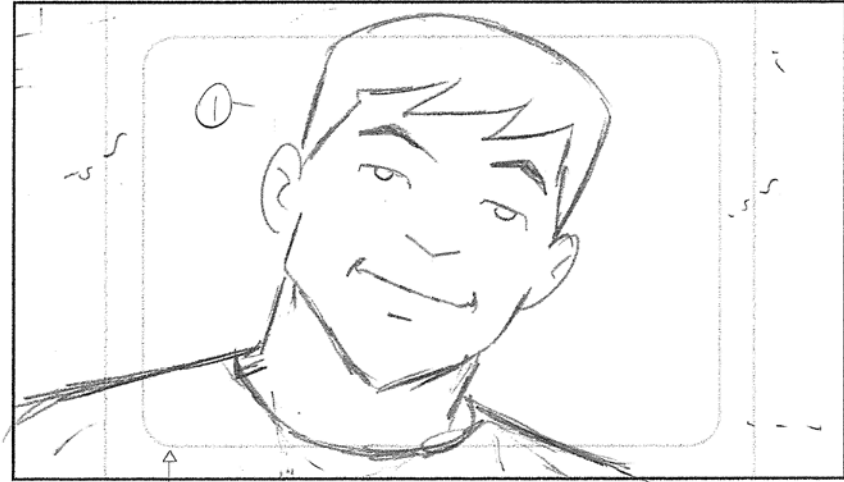

4:3 TV Safe Location: Day Night Other 16:9

Action

Thug #1 is pleased all is going well

Dial

SLG

Trans

SC CONT PANEL B BG. 3

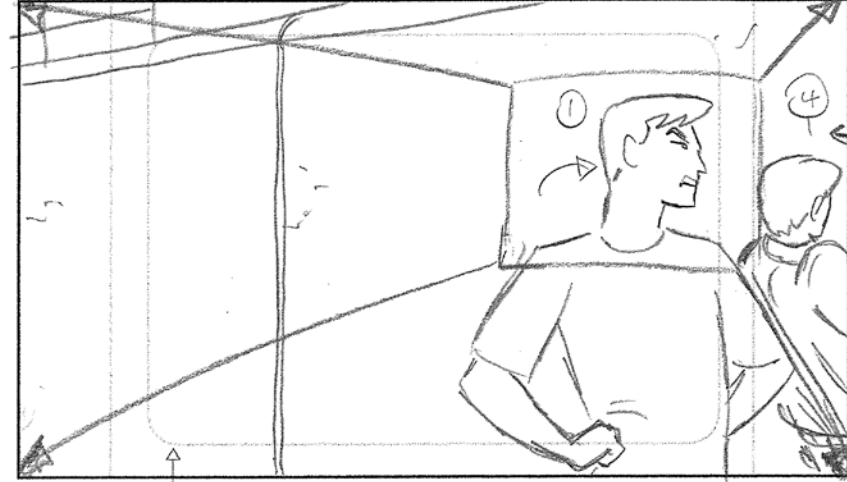

4:3 TV Safe Location: Day Night Other 16:9

Action

#1 turns head quickly as #4 enters frame. Zoom out as Thug #4 enters frame

Dial

SLG

Trans

SC CONT PANEL C BG. 3



4:3 TV Safe Location: Day Night Other 16:9

Action Thugs # 4 + 5 enter frame

Dial THUG # 1
Hurry up with that!

SLG

Trans

CUT SC 3 (IN) PANEL A BG. 4

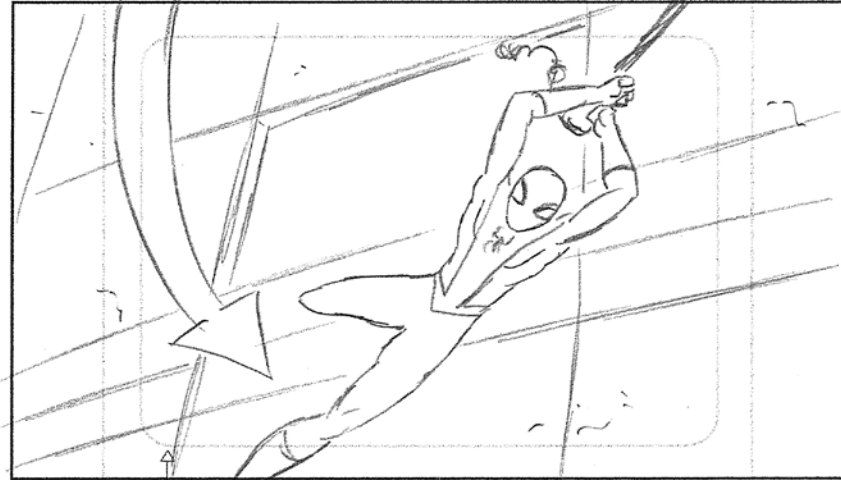

4:3 TV Safe Location: Day Night Other 16:9

Action POS 1 OF TRUCK OUT AS SPIDEY J WINGS INTO FRAME

Dial

SLG

Trans

SC PANEL BG.

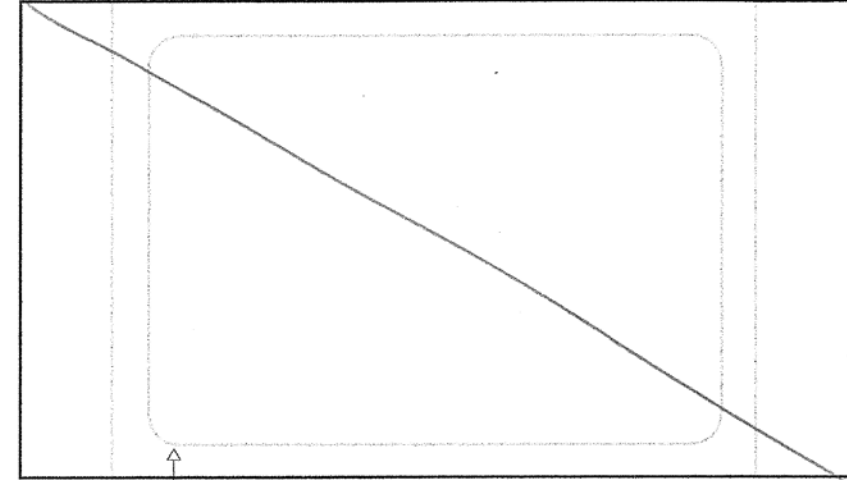

4:3 TV Safe Location: Day Night Other 16:9

Action (SC) →

Dial

SLG

Trans

SC CONT PANEL B BG. 4 SC PAN PANEL BG. SC PANEL BG. STOP

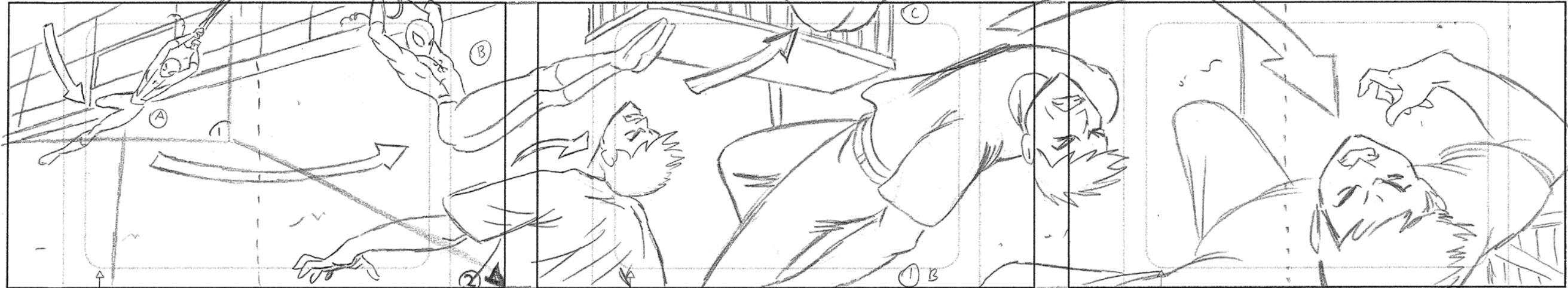

4:3 TV Safe Location: Day Night Other

16:9 ① A 4:3 TV Safe Location: Day Night Other

16:9 ① B 4:3 TV Safe Location: Day Night Other

16:9 ① C 4:3 TV Safe Location: Day Night Other

16:9 ① C 4:3 TV Safe Location: Day Night Other

Action TRUCK OUT AND PAN WITH SPIDEY, THEN THUG ①

Action SPIDEY SWINGS THROUGH AND OS
OS spidey's feet slam into thug #1's head who falls toward camera

Action KICKED OS

Dial

Dial

Dial

SLG

SLG

SLG

Trans

Trans

Trans

CUT
SC 4

PANEL A BG. 5

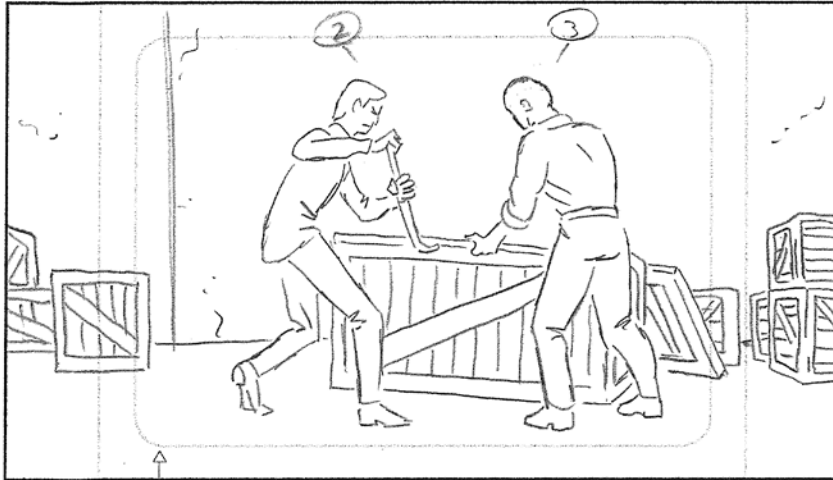

4:3 TV Safe Location: Day Night Other

Action

Dial

SLG

Trans

SC CONT PANEL B BG. 5

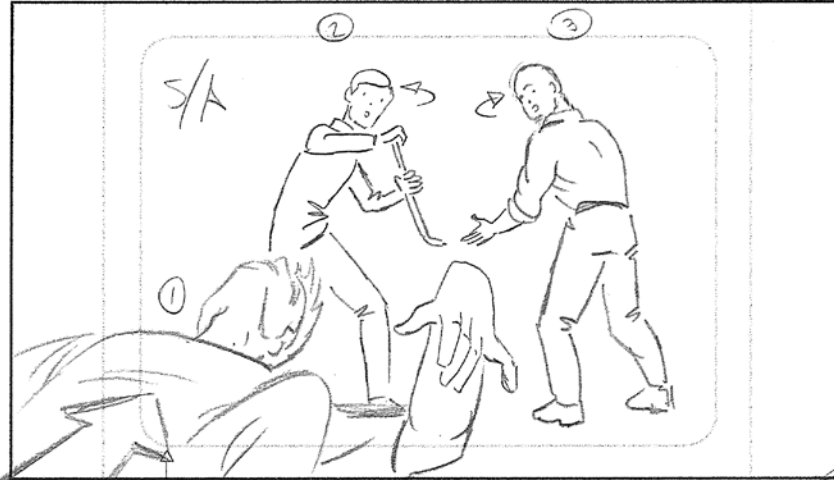

16:9 IN 4:3 TV Safe Location: Day Night Other

Action Thug #1 sails past camera

Dial

SLG

Trans

SC CONT PANEL C BG. 5

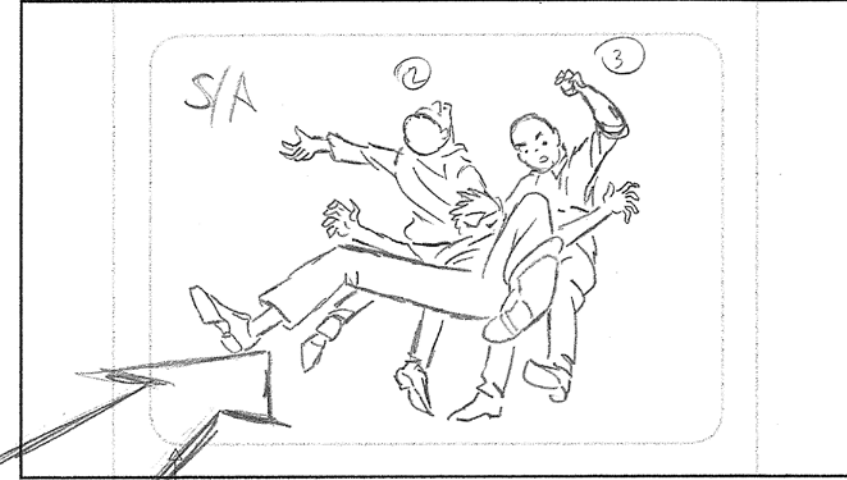

16:9 4:3 TV Safe Location: Day Night Other

Action into + hugs # 2 & 3

Dial

SLG

Trans

Howard Simpson

818-288-5931

jobz@abbadabba.com

CUT
SC 5

PANEL A BG. 6

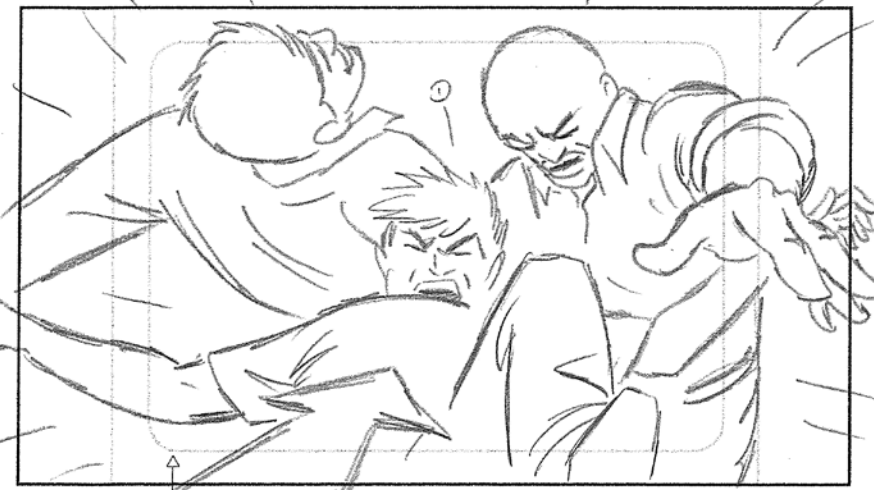

4:3 TV Safe Location: Day Night Other 16:9

Action

Dial

SLG

Trans

SC CONT PANEL B BG. 6

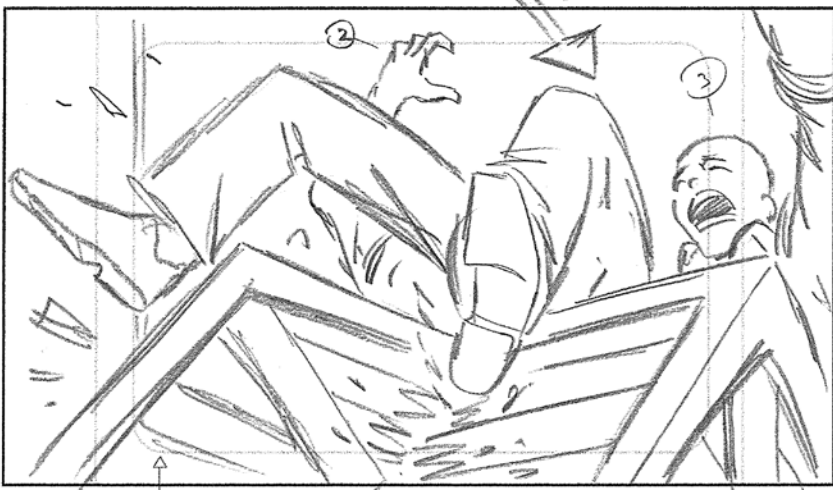

4:3 TV Safe Location: Day Night Other 16:9

Action

Dial

SLG

Trans

SC CONT PANEL C BG. 6

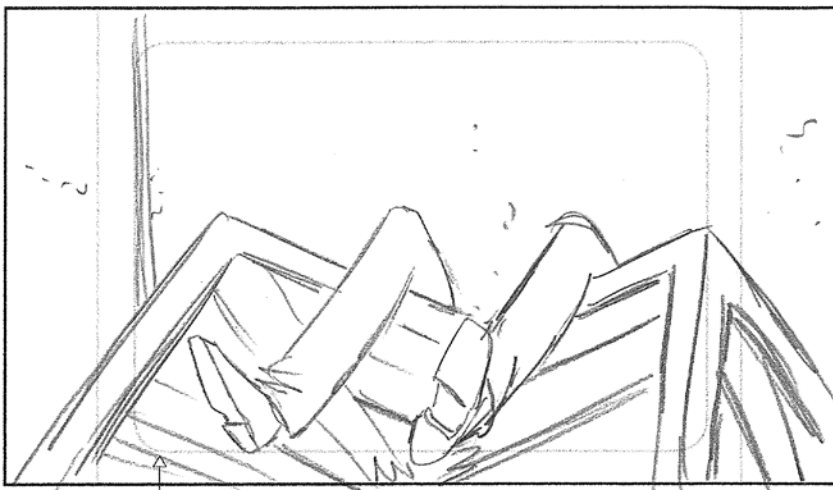

4:3 TV Safe Location: Day Night Other 16:9

Action

Dial

SLG

Trans

CLT
SC 6 PANEL A (14) BG. 7

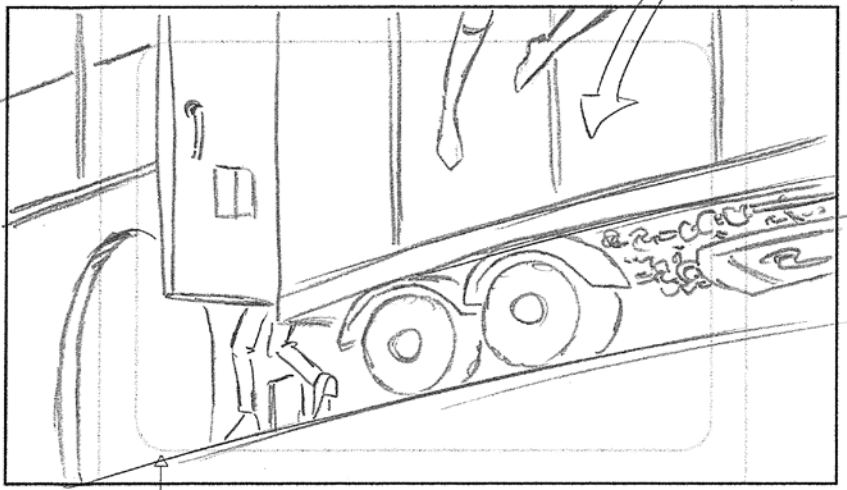

4:3 TV Safe Location: Day Night Other 16:9

Action
Spidey lands into scene
Thug # 6 is hidden behind truck

Dial

SLG

Trans

SC CONT PANEL B S/A BG. 7

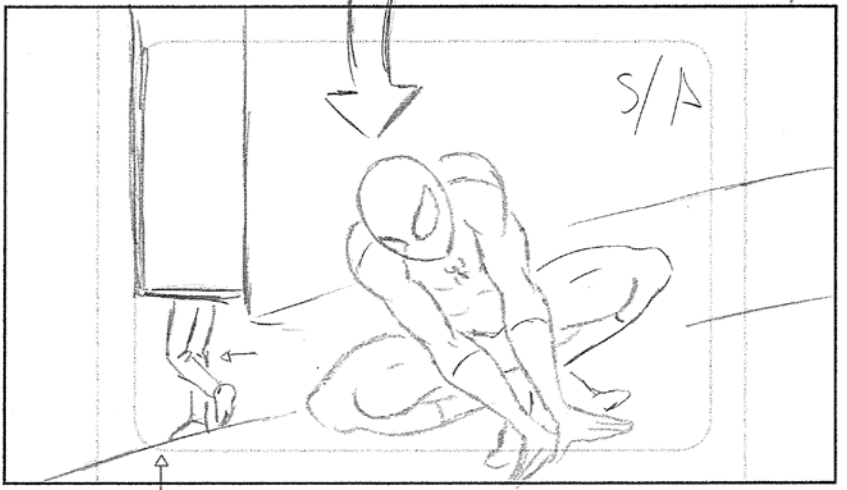

4:3 TV Safe Location: Day Night Other 16:9

Action
Thug # 6 moves towards edge of door.

Dial

SLG

Trans

SC CONT PANEL C BG. 7

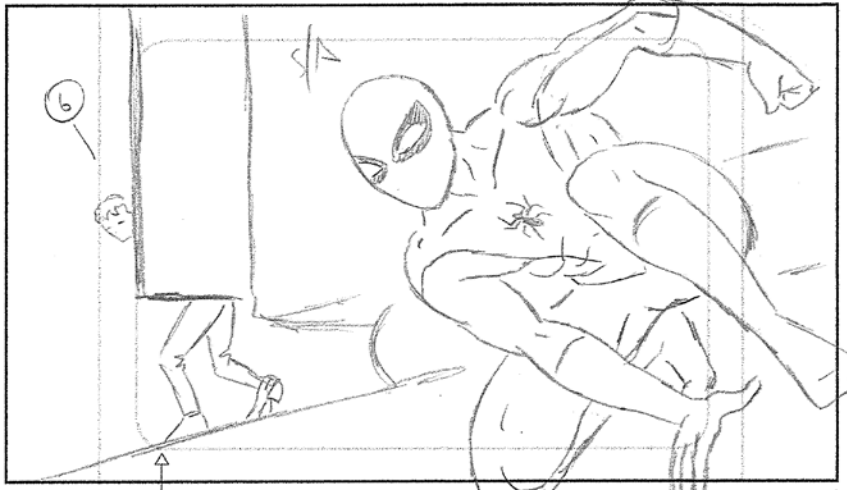

4:3 TV Safe Location: Day Night Other 16:9

Action
Thug # 6 peeks out quickly

Dial

SLG

Trans

CUT SC 7 PANEL A BG. 8



4:3 TV Safe Location: Day Night Other 16:9

Action

Dial

SLG

Trans

SC CONT PANEL B BG. 8

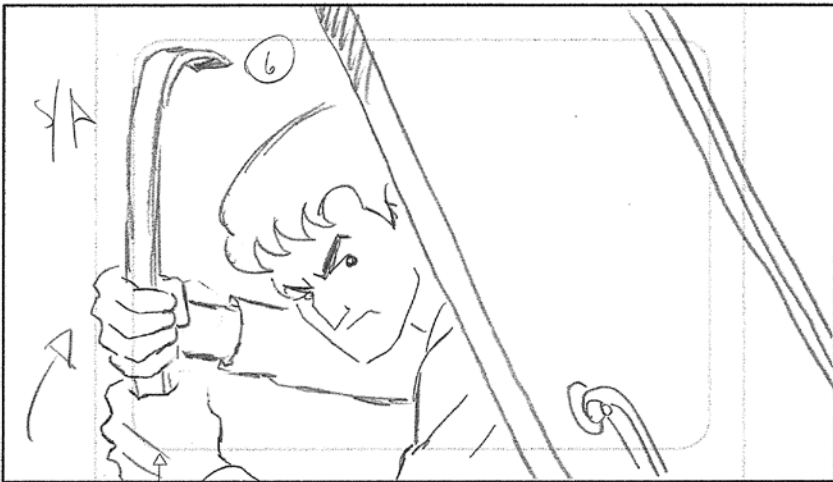

4:3 TV Safe Location: Day Night Other 16:9

Action

Thug # 6 gets his courage up thanks to handy crow bar

Dial

SLG

Trans

CUT SC 8 PANEL A BG. 9

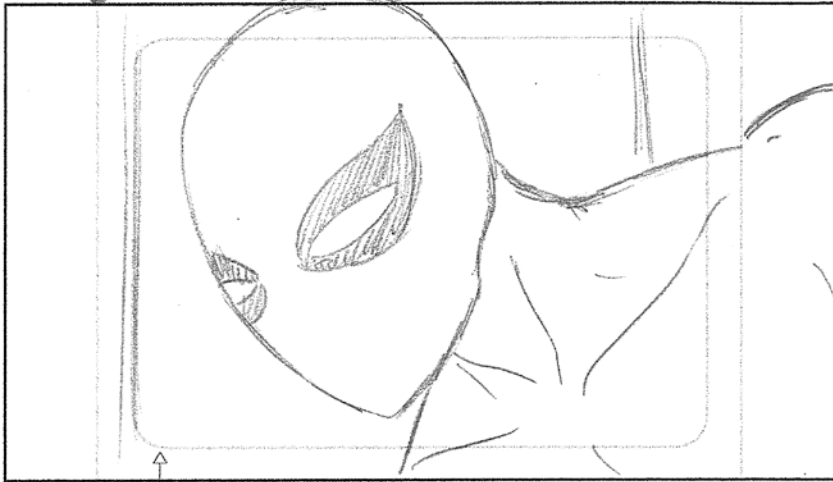

4:3 TV Safe Location: Day Night Other 16:9

Action

EYES widen SC → Spider-sense tingles

Dial

SLG

Trans

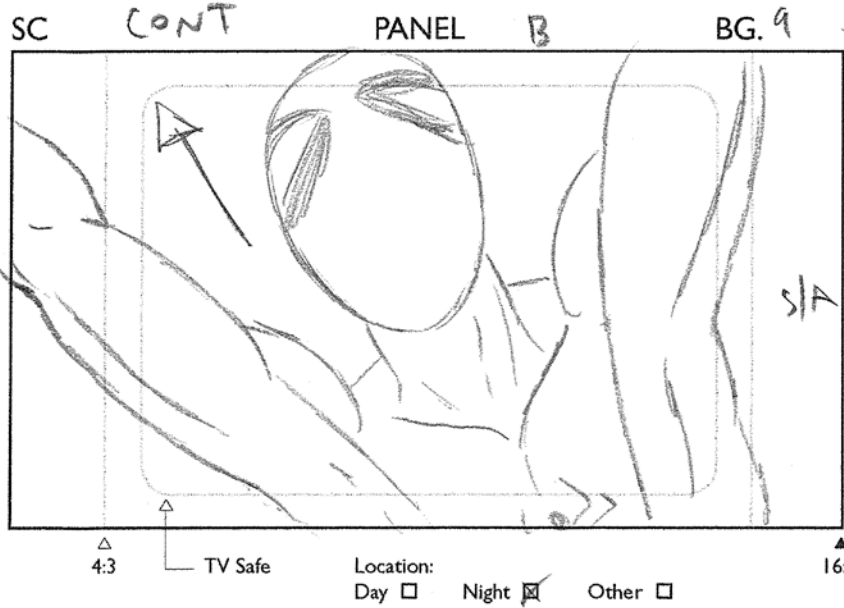

Action
spidey flips upward quickly

Dial

SLG

Trans

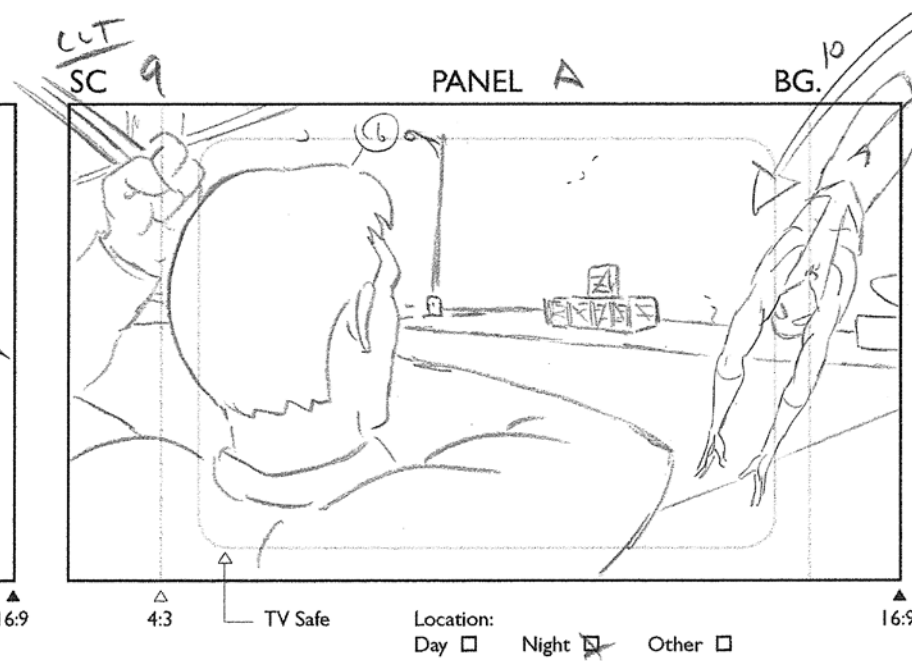

Action

Dial

SLG

Trans

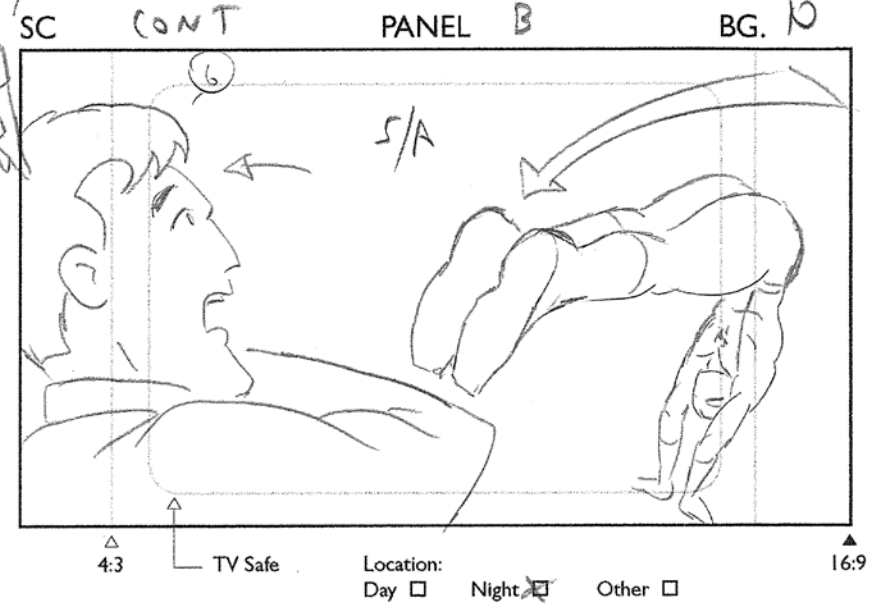

Action

Dial

SLG

Trans

CUT SC 10 PANEL A BG. 11

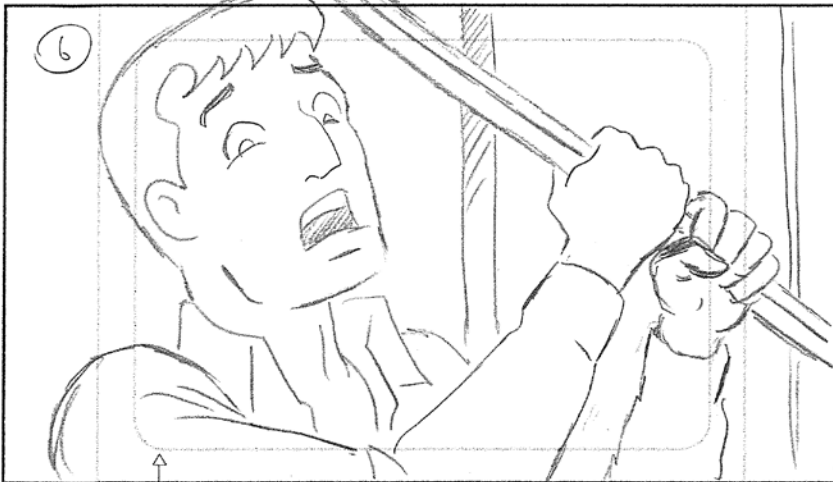

4:3 TV Safe Location: Day Night Other 16:9

Action

Dial Thug # 6

<grunt, whoa>

SLG

Trans

SC CONT PANEL B BG. 11

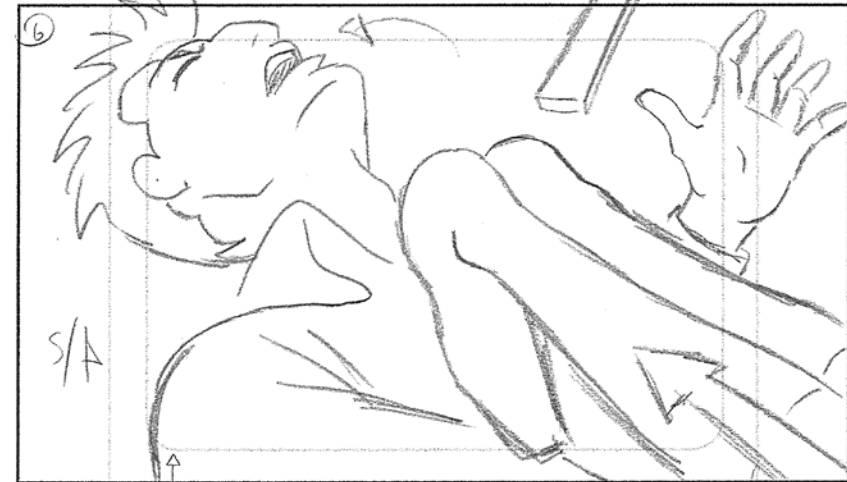

4:3 TV Safe Location: Day Night Other 16:9

Action

Dial THUG # 6

<AAH!>

SLG

Trans

CUT SC 11 PANEL A BG. 12

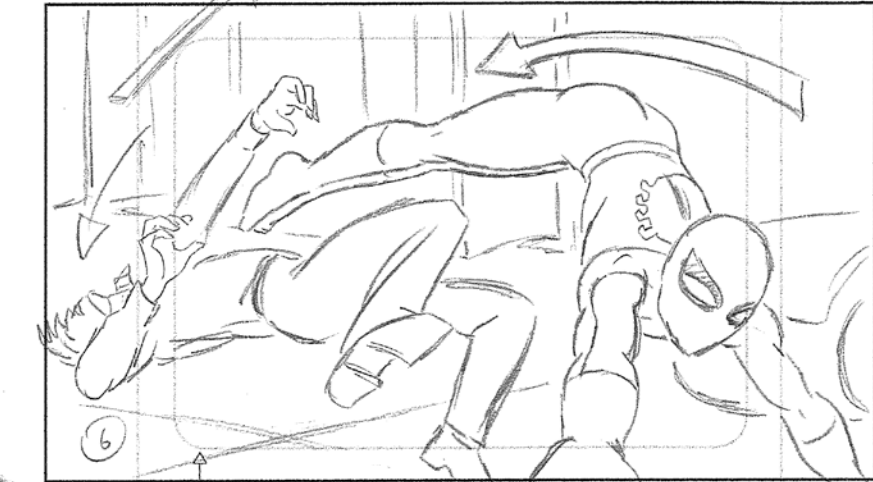

4:3 TV Safe Location: Day Night Other 16:9

Action

Dial

SLG

Trans

^{CUT}
SC 12 PANEL A BG. 13

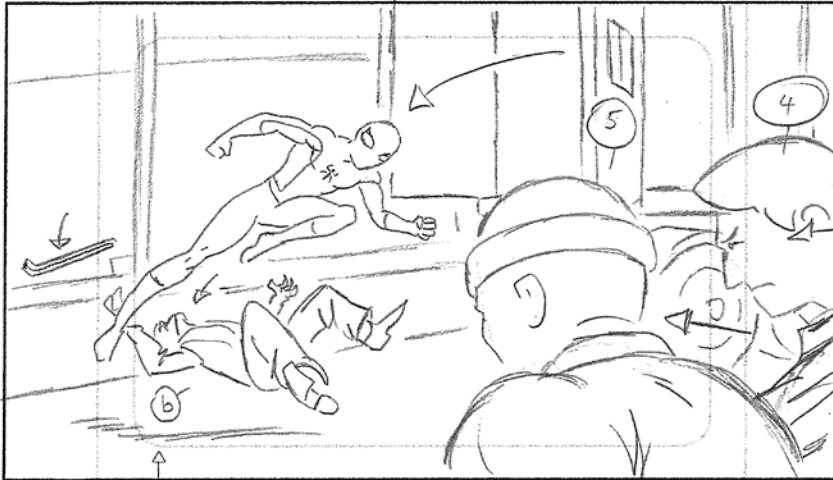

4:3 TV Safe Location: Day Night Other 16:9

Action
Thugs # 4 + 5 run in from OS

Dial

SLG

Trans

^{CUT}
SC 13 PANEL A BG. 14

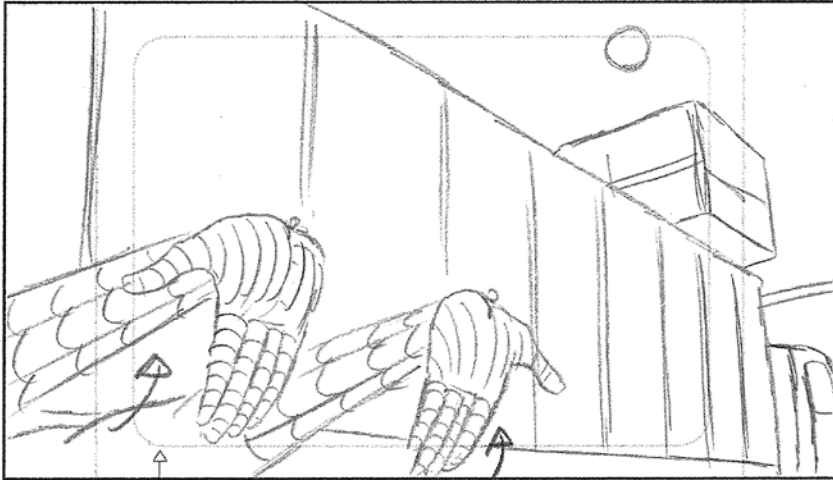

4:3 TV Safe Location: Day Night Other 16:9

Action

Dial
PETER (VO)
This is _____ →

SLG

Trans

SC CONT PANEL B BG. 14

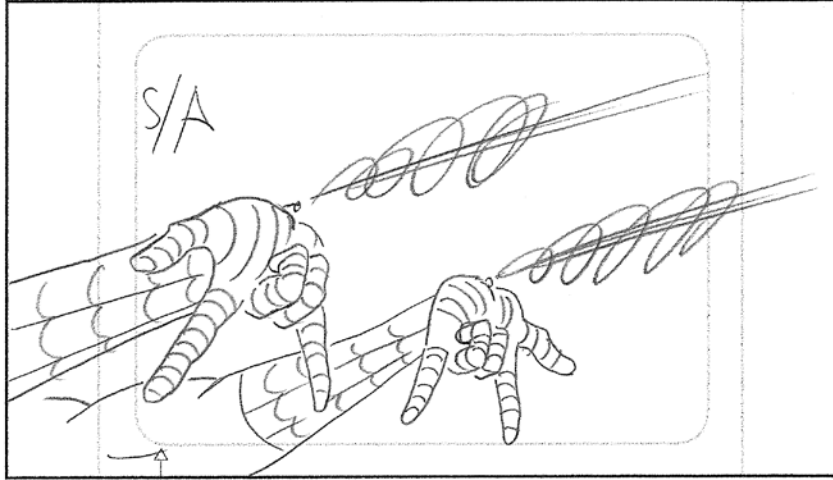

4:3 TV Safe Location: Day Night Other 16:9

Action

Dial
PETER (VO)
_____ → the fifth _____ →

SLG

Trans

CUT
SC 14

PANEL A

A

BG. 15

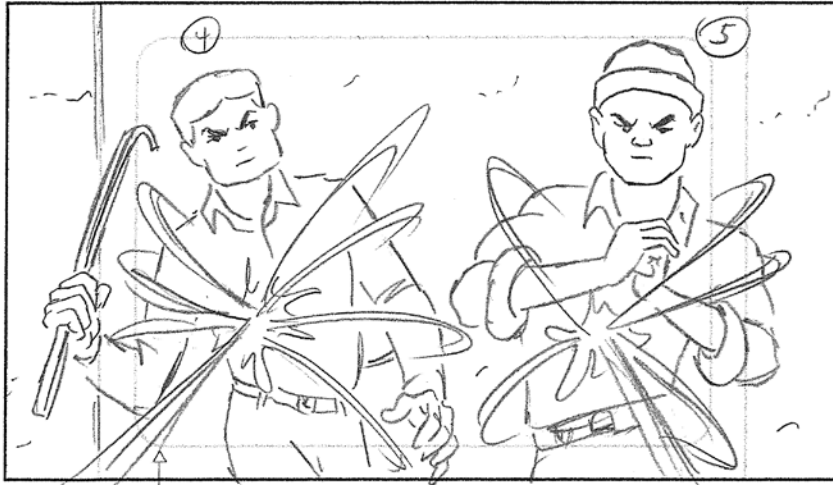

4:3 TV Safe Location: Day Night Other 16:9

Action

Dial

PETER (VO)

→ Cab Squad →

SLG

Trans

SC CONT

PANEL B

BG. 15



4:3 TV Safe Location: Day Night Other 16:9

Action

Dial

PETER (VO)

live fought →

SLG

Trans

SC CONT

PANEL C

BG. 15



4:3 TV Safe Location: Day Night Other 16:9

Action

Dial

PETER (VO)

in a, many nights →

SLG

Trans

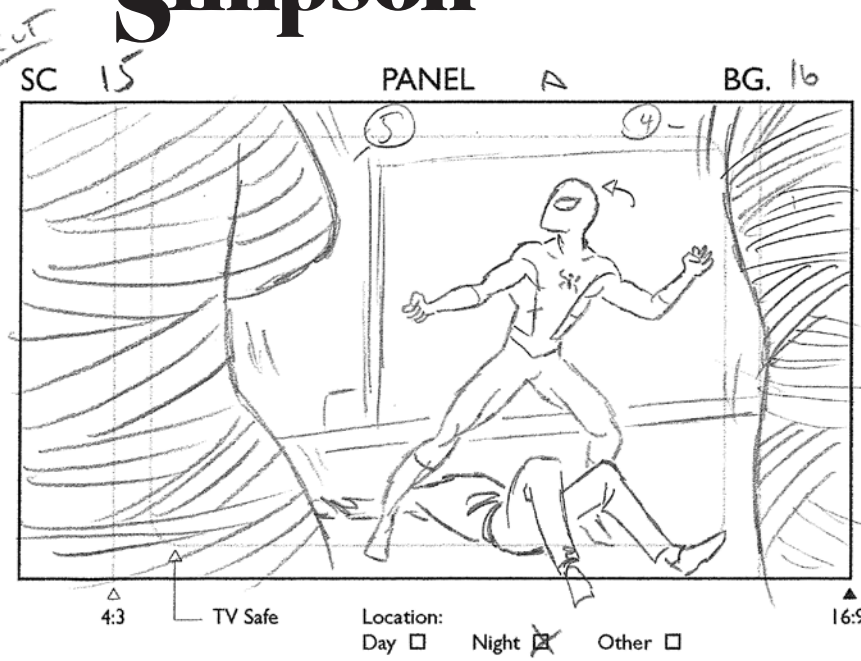

Action

spidey scans his surroundings

Dial PETER (vo)

And still

SLG

Trans

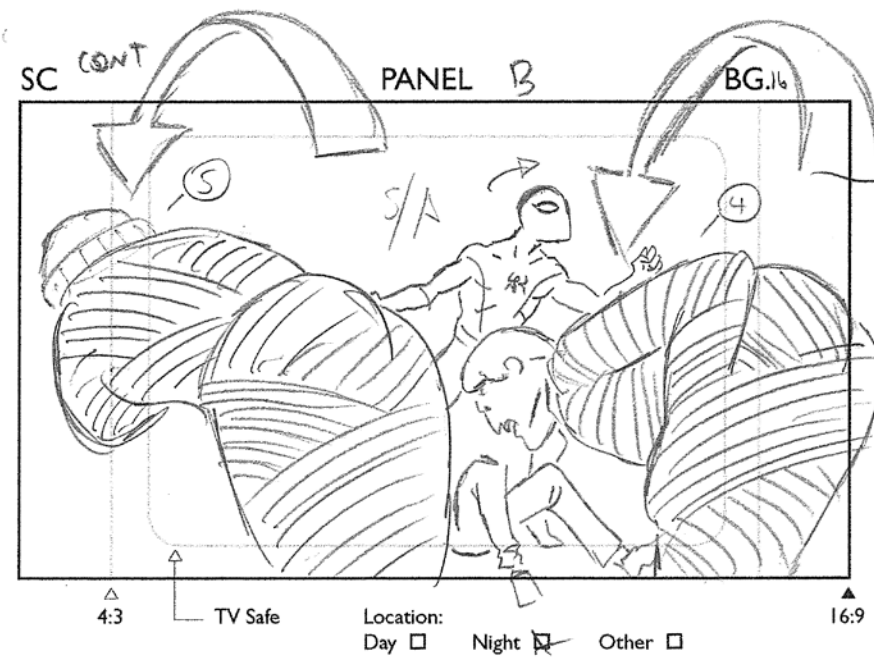

Action

looking for the Green Goblin

Dial PETER (vo)

no sign

SLG

Trans

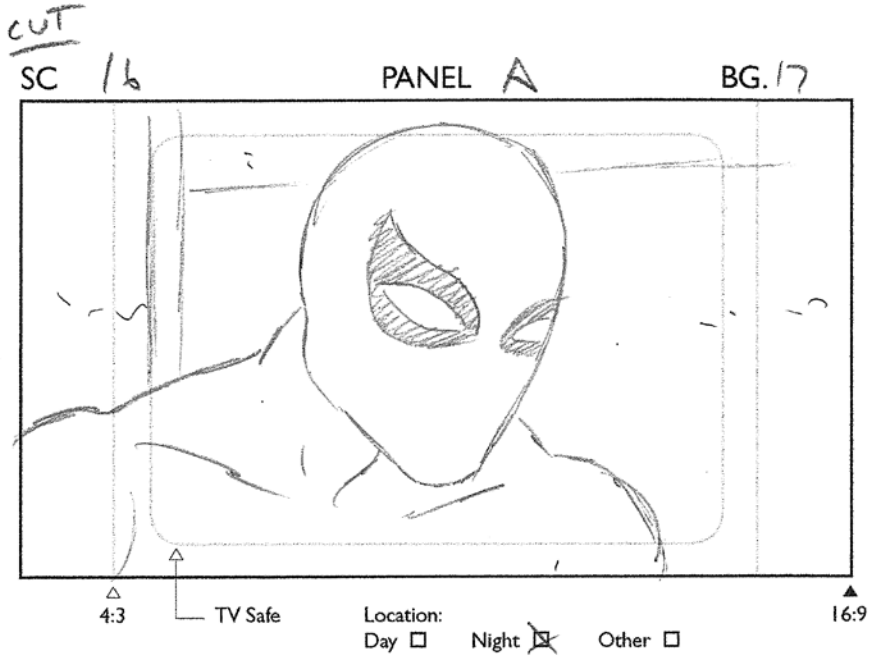

Action

Dial PETER (vo)

of their boss

SLG

Trans